

Causal necessity, causal sufficiency, and the implications of causative verbs

Sven Lauer Prerna Nadathur

Abstract Against past analyses, we propose that natural language causatives do not universally encode a single, unanalyzable ‘bringing about’ meaning like Dowty’s (1979) CAUSE, but instead draw on an inventory of contrasting causal dependency relations. To illustrate this claim, we focus on the English causative verbs *make* and *cause*. We point out a number of differences in their inferential profiles, and argue that these follow from the fact that *cause* asserts a relation of **causal necessity** between a cause and its stated effect, while *make* asserts **causal sufficiency**. We distinguish these notions from their alethic counterparts: while causal necessity is similar to the notion of counterfactual necessity (Lewis 1973), causal sufficiency has not figured in previous analyses of causal language. We show that analyzing *make* as a sufficiency causative not only accounts for the similarities and differences between its distribution and that of *cause*, but also enables us to explain previously puzzling inferential patterns associated with the use of *make* as opposed to other periphrastic causative verbs.

Keywords: causative, *cause*, *make*, sufficiency, necessity, causal models

1 Introduction

At the outset of his influential paper on causation, David Lewis (1973) reminds us that:

Hume defined causation twice over. He wrote “we may define a cause to be *an object followed by another, and where all the objects, similar to the first, are followed by objects similar to the second*. Or, in other words, *where, if the first object had not been, the second never had existed*.”

The most puzzling aspect about the two definitions is the phrase that appears between them: *in other words*. The two definitions do not seem to

say the same thing at all. Lewis, who favours the second definition, focuses on the idea that the first definition is about an (actual) regularity, while the second deals with counterfactual possibility.

There is another difference between the two definitions, however, which is perhaps even more glaring. Hume's second definition takes a cause to be something that is (counterfactually) *necessary* for its effect: that is, something without which there was no possibility of the effect being realized. His first definition, however, does not involve necessity at all. Instead, it describes a relation of sufficiency. Lewis makes this explicit in his summation of theories in the spirit of the first definition:

[...] a cause is defined (roughly) as any member of any minimal set of actual conditions that are jointly sufficient, given the laws, for the existence of the effect.

In drawing the two definitions apart, Lewis's aim is to advocate for a (now-familiar) counterfactual theory of causation, in place of the regularity hypotheses inspired by the first definition. In this paper, we argue for a reinstatement of the sufficiency option, as a description of a type of causation that exists independently and alongside the kind of causal relation that Lewis focused on.

Our central concern is the semantic analysis of periphrastic causative verbs in natural language, rather than with the abstract concept of causality *per se*. Our thesis has a bearing on causation more broadly insofar as it distinguishes different types of causal connections: specifically, we argue that the semantics of causative verbs makes reference to (at least) two independent types of causal dependence. One notion, **causal necessity**, is in the spirit of Hume's second definition. Necessity deals with causal relationships in which the object or event distinguished as a cause is taken to render its effect possible; thus, it is closely connected to Lewis's influential analysis of *cause* as counterfactual necessity. The second notion, **causal sufficiency**, more closely tracks Hume's first suggestion (though we dispense with the idea of regularity). Sufficiency deals with causal relationships in which a cause guarantees its effect: in other words, in which a cause renders its effect not only possible, but inevitable.

By focusing on the semantic contrast between two English periphrastic causatives, *cause* and *make*, we show that natural language must make reference to at least these two relations of causal dependence. We go on to show that causal necessity and causal sufficiency represent relations that cannot be spelled out in terms of purely alethic or logical relations (nor, as it turns

out, in terms of one another). Rather, these relations represent concise ways of describing certain configurations or pathways in a complex network of causal dependencies between events, which forms part of our knowledge of the world. To a certain extent, causal necessity and sufficiency parallel their logical counterparts, which, for their part, represent concise ways of talking about certain configurations of analytical relations.

A larger consequence of the semantic analysis we pursue here is the thesis that causal links and dependence relations belong to the set of abstract concepts and objects which we manipulate and describe with natural language. Ultimately, we believe that dependency relations like causal necessity and causal sufficiency have a role to play as atoms of lexical semantic analysis, even outside the domain of words like *cause*, *make*, and other causative verbs, which (so to speak) wear their association with concepts of causality on their sleeves.

2 Causes, effects, and causal implications

English, like other languages, employs a range of verbs for describing causal connections between two events. The periphrastic causatives *cause*, *make*, *have*, and *get* illustrate some of this diversity: each of (1a)-(1d) provides a asserts that a particular event (some action taken by Gurung) is causally involved in the realization of a second event (the children dancing).

- (1) a. Gurung caused the children to dance.
 b. [?]Gurung made the children dance.¹
 c. Gurung had the children dance.
 d. Gurung got the children to dance.

What is striking about the juxtaposition of these four statements is the strong intuition that – despite the fact that they all describe a causal relationship between the same two events – they do not describe the same situation or chain of causation. (1b), for example, suggests that Gurung employed force or authority over the children in order to compel them to dance, regardless of their personal inclinations. (1c), on the other hand, seems to describe a chain of events in which Gurung issued a straightforward order or instruction to the children, which they then obeyed without resistance or objection. Yet again different, (1d) suggests that, while Gurung wanted

¹ We use the diacritic [?] to indicate that a sentence was found on the internet, following the practice of Horn (2010). Sources for all naturally-occurring examples can be found in the appendix.

the children to dance, he faced some difficulty in achieving this goal, and had to employ effort or ingenuity to do so, perhaps by bribing the children with a reward of some kind. Finally, in contrast to (1b)-(1d), the use of *cause* in (1a) does not imply anything about Gurung's desires or intentions, but conveys, if anything, that the causal link between Gurung and the children dancing was somehow 'indirect': felicitously describing, for instance, a chain of events in which Gurung inadvertently brought about the dancing, perhaps by putting on some energetic music, which independently motivated the children to dance.

A (comparative) semantic analysis of the causatives in (1) must deal centrally with two questions. First, what is the semantic or logical representation of the meaning shared by *cause*, *make*, *have*, and *get* (as well as other periphrastic causatives such as *force*, *let*, and *enable*), which predicates causation between Gurung's action and the children dancing? Second, what accounts for their divergence, producing the inferences described above, which deal with features of a causal chain such as causer/causee intention and volition?

At first glance, it seems like there should be a relatively simple way to address these two questions. A reasonable first analysis of the verbs in (1) is that they share a semantic core, represented by CAUSE (which might be equivalent to natural language *cause*). CAUSE would capture the essential features of the causal assertion: that both cause and effect events occurred, and that the causing event was responsible for bringing about the effect event. To this core of meaning, each of the verbs in (1) would add certain specific entailments, pinning down details of the causal participants (causer, causee) and/or the context of causation. *Make*, *have*, and *get* might, for example, all be associated with an entailment to the effect that the causer's action was intended to produce the effect, while only *make* plausibly entails that the causee was unwilling or otherwise resistant to participating in the effect event.

On the CAUSE hypothesis, our task as semantic analysts would reduce to (a), choosing or developing an analysis of the semantic object CAUSE, and (b), establishing the form and content of the additional entailments specific to each causative verb. Neither of these is a trivial task: quite apart from the well-known difficulty of establishing a satisfactory definition of causation, it turns out that attempting to pin down the 'extra' entailments of a verb like *make* leads us quickly into an apparent contradiction.

2.1 The many faces of *make*

In addition to the inferences of causer intention (i) and causee resistance (ii), the inferences in (iii)-(v) have been put forward as candidates for entailments that are specific to the periphrastic causative *make*. These hold up quite well in the context of (1b):

- (i) that Gurung intended to bring about the dancing (Wierzbicka 1998);
- (ii) that the children were unwilling to dance
(‘coercive causation’, Dixon 2005; Shibatani 1976);
- (iii) that Gurung commanded or requested that the children dance
(‘directive causation’, Shibatani 1976);
- (iv) that Gurung wanted the children to dance (Stefanowitsch 2001);
- (v) that the children were aware that Gurung wanted them to dance
(Wierzbicka 1998).

Once we consider a wider range of examples, however, none of these inferences can be maintained as potential entailments of *make*. An example like (1b) can at most implicate (and not entail) causer intent or desire, because causative *make* occurs felicitously in examples where these features are explicitly denied.

- (2) a. ?Yes, I accidentally made [my 3-year old son] fall off the boogie board because holding the board and two bottles of fish food was a little much.
- b. ?Took a picture of my cat and accidentally made him look like a villain!
- c. ?Instead of motivating him to improve, you’ve inadvertently made him tune you out.
- d. ?How Time-Poor Scientists Inadvertently Made It Seem Like The World Was Overrun With Jellyfish. [headline]
- e. ?These were what caused our dog problems back at Lauderdale when I inadvertently made her walk through an area of bush without realizing what I was doing.
- f. ?Jackie Hoffman on How Jessica Lange Unintentionally Made Her Cry [headline]
- g. ?I was panicking and I unintentionally made my friend worry by mentioning the storm through a WhatsApp message and then leaving my phone in my bag, without relaying a message back that everything was actually ok.

Nor can *make* assert unwillingness or resistance on the part of the causee, since we readily find acceptable *make*-causatives in which the outcome is presumably desirable to the causee.

- (3)
- a. ?I was scared, but they made me feel confident
 - b. ?Demi has previously admitted her mother Diana is her “anchor”, and has made her feel positive about her future once again.
 - c. ?Then a surprise surgery and hospital stay at the age of 13 brought Albert in contact with nurses who made her feel happy and important during a stressful situation.

To complicate the picture further, it is not even possible that *make* simply asserts volitionality for its causer and causee. Once again, examples (4a-d) provide perfectly good uses of causative *make* with eventive causes, inanimate causers and causees, and effects involving involuntary (non-volitional) actions.

- (4)
- a. ?His father’s death made him turn to the team as family.
 - b. ?This book made me get a divorce
 - c. ?Too much water made the plant die because the roots rotted in the water
 - d. ?Stop saying Mussolini made the trains run on time.

These data put us in a difficult position. It is hard to see, based on the range of uses for causative *make*, what the viable candidates are for entailments that *make* adds to a CAUSE core. On the other hand, the use of *make* clearly contrasts with each of the alternative periphrastic causatives in (1). Similarly, the use of *make* in the preceding examples contrasts with the causatives chosen in (5)-(6), where we have simply substituted *have* or *get* for *make*, *modulo* some minor syntactic changes to the causative complements to preserve grammaticality.

- (5)
- a. These were what caused our dog problems back at Lauderdale, when I inadvertently **had** her walk through an area of bush...
 - b. Jackie Hoffman on How Jessica Lange (#unintentionally) **had** her cry.
 - c. (?)This book **had** me get a divorce

- (6)
- a. Instead of motivating him to improve, you inadvertently **got** him to tune you out.
 - b. I was panicking and I **got** my friend to worry by mentioning the storm through a WhatsApp message ...
 - c. Then a surprise surgery ...brought Albert in contact with nurses who **got** her to feel happy and important during a stressful situation.
 - d. Stop saying Mussolini **got** the trains to run on time.

More striking still, there are contexts in which *cause* is appropriate, but *make* is not:

- (7)
- a. ?...the storm caused [...] a “historic high tide” to flood coastal towns.
 - b. ??...the storm made [...] a “historic high tide” flood coastal towns.

This is clear evidence that *make* entails something which *cause* does not: but what can this be? We seem to have been painted into an analytic corner.

Against past analyses of *make*, which resort to treating it as polysemous (Wierzbicka 1998; Stefanowitsch 2001), we contend that the way out of the corner involves reconsidering our first hypothesis about the shared core of periphrastic causatives. In the next section, we show that the differences between *cause* and *make* statements are best explicated by giving up the idea that the notion of causation expressed by various causatives can be captured by a single relation, CAUSE. Instead, different causatives describe different ways of being a cause: in other words, they describe different types of causal dependence relations. The chief distinguishing feature of any causative verb, on our new hypothesis, boils down to the nature of the causal relation it predicates. Thus, while *cause* describes a relation of causal necessity, we argue that *make* instead predicates a type of causation more akin to Hume’s first definition: use of *make* entails that the causing event sufficed to guarantee the effect. Treating *make* in terms of causal sufficiency (to be spelled out in more detail in §3) allows us not only to predict the contrasts between *make* and *cause*, but also to predict and explain the inferences that arise only from *make* in examples like (1).

2.2 Two kinds of causal dependence

We have already seen that *cause* is felicitous in contexts where *make* is not, suggesting that *make* carries a component of meaning which *cause* lacks. As it turns out, there are also contexts in which *make* is felicitous, but *cause* is

not, as we will see in §2.2.3. This suggests, in turn, that *cause* carries an entailment that is not part of the meaning of *make*. We want to suggest that the meaning specific to *cause* is one of causal necessity.

2.2.1 Counterfactual necessity

Following Lewis (1973), many authors associate *cause*-statements like (8a) with a counterfactual conditional like (8b) that links the specified cause and effect.

- (8) a. In total, the Napa fires caused the Vine Transit system to lose approximately \$68,000 in revenue.²
 b. If the Napa fires had not occurred, the Vine Transit system would not have suffered a \$68,000 revenue loss.

Lewis takes the counterfactual statement to be in a sense constitutive of the causal relationship described by *cause*.³ *Cause* is thus taken to describe a relation in which the occurrence of the cause (possibly in conjunction with other events, which are left in the background by the *cause*-statement), moves us from a state in which the occurrence of the event was impossible to one in which it is possible: that is, a state where the effect is realized in at least one accessible world.

A number of authors, including Shibatani (1976), have taken for granted that the truth of *make* is similarly tied to the truth of a counterfactual statement. Shibatani treats *make* as a hyponym of *cause* (along the lines of our problematic first hypothesis). Wierzbicka (1998), despite treating *make* as multiply ambiguous, places a statement of counterfactual necessity at the center of each of her *make* constructions. A general form for Wierzbicka's 1998 inferences is given in (9). Examples (10)-(12), and the counterfactual statements associated with them, are drawn from just three of the many *make*-constructions she identifies:

² Slightly modified from the original, see appendix.

³ Later work (e.g. Lewis 2000) significantly revised the counterfactual theory, so that the counterfactual in (8b) itself would no longer be taken to be constitutive of the causal relation. However, counterfactual statements similar to (8b) remain important in Lewis's 2000 definition of *causal influence*, which in turn is central, in the later work, to the definition of *cause*.

- (9) $\left. \begin{array}{l} \left\{ \begin{array}{l} Z \text{ would not have happened (to } Y) \\ Y \text{ would not have done } Z \end{array} \right\} \text{ if } \left\{ \begin{array}{l} X \text{ had not done something} \\ X \text{ had not happened} \end{array} \right\}$
 where Y is the causee, X is the causer or causing event, and Z the eventuality denoted by the embedded VP.
- (10) Interpersonal *make* of ‘coercion’
- a. She [Anand’s mother]...made Anand pump the tires [of the bicycle] every morning.
 - b. Anand would not have pumped the bicycle’s tires without some action taken by his mother.
- (11) Impersonal *make* of ‘subjective necessity’
- a. A sharp hiss made her [Alice] draw back in a hurry.
 - b. Alice would not have drawn back (so quickly) if the sharp hiss had not occurred (or if it had been less sharp).
- (12) Impersonal *make* of ‘surprise’
- a. The wind made the door slam shut.
 - b. The door would not have slammed shut if it had not been affected by the wind.

Although the counterfactuals do to some degree appear to be licensed by the *make*-causatives, closer consideration of these examples shows that the (b) statements cannot be part of the asserted content of the (a) statements.

2.2.2 Sufficiency instead of necessity

Examples (11) and (12) are well-paraphrased by statements using *prompt* or *trigger* (cf. Stefanowitsch 2001).⁴ Neither (13) or (14) suggests that the described effect was impossible prior to its prompt or trigger. Instead, these paraphrases suggest an immediacy or inevitability relationship, in which the

⁴ Stefanowitsch (2001) distinguishes three types of *make*-causative, involving *manipulation*, *triggering* and *prompting*. Manipulation involves two animate participants. In a triggering *make*-causative, the causing event X (which may or may not have an intentional agent) influences an entity Y in such a way that Y cannot but undergo a particular action or change, named in the resulting event. Stefanowitsch calls this ‘the *make*-causative of involuntary processes’. In a prompting event, a causing event X (again with or without an intentional agent) is perceived by an intentional agent Y , who reacts by voluntarily performing the resulting action: this is ‘the *make*-causative of decision’. Both triggering and prompting events are subsumed under the *make* we develop here: we will see the relevance of causee decision in §4.1.

causing event simply guaranteed the realization of the effect, as and when it occurred.

- (13) A sharp hiss prompted Alice to draw back in a hurry.
- (14) The wind triggered the slamming of the door.

The idea that *make* predicates inevitability rather than counterfactual necessity can also be recruited to explain the infelicity of *make* as opposed to *cause* in (7). Specifically, world knowledge tells us that events like high tides and floods are products of a number of forces coming together (current climate conditions, the position of the moon, the time of day, etc). Thus, while the storm referred to in (7) (the ‘bomb cyclone’ of January 2018) is plausibly a contributing factor, without which the high tide/flood would not have been possible, it is extremely unlikely, given what we know about the world, that the storm was sufficient to produce the flood.

This contrast between necessity, which creates the possibility of an effect, and sufficiency, which renders an effect inevitable, is even clearer in the following example, taken from a 2009 installment of the Rachel Maddow show (MSNBC, Monday August 10, 2009; emphasis added).

- (15) MADDOW: You worked for [the health insurance company] CIGNA for 15 years, you left last year. What **caused** you to change your mind about what you were doing and leave?
 POTTER: Well, two things. One, it was kind of gradually. One instance or in one regard because I was becoming increasingly skeptical of the kinds of insurance policies that the big insurance companies are promoting and marketing these days. [...]
 The other thing that really **made** me make this final decision to leave the industry occurred when I was visiting family in Tennessee a couple of summers ago, and [narrates the experience of happening on a ‘healthcare expedition’ where uninsured patients were treated by volunteer doctors in animal stalls at a fairground.]

Potter says that there were two contributing factors to his decision to leave his job: his growing unease about the practices of the big health insurers, and the visit to the healthcare expedition. About the latter, he says that it *made* him take the final decision. But he clearly does not assert therewith that he would not have left CIGNA if he had not visited the expedition: he might well have been convinced by his growing unease. What Potter *does* assert is that the healthcare expedition made his decision to quit a done

deal. Before the expedition, his departure was not guaranteed; afterwards, it was imminent and, crucially, inevitable.

2.2.3 Denying necessity and sufficiency

Finally, we can compare the use of *cause* and *make* in contexts which explicitly deny either a necessity or a sufficiency inference. In (16), the speaker begins by establishing the possibility that she will not go to soccer camp, thus precluding the necessity entailment spelled out in (16b).

- (16) a. I usually go to soccer camp in the summer. Last year I was thinking about going to band camp instead, and I could not make up my mind. Then I broke my ankle, which settled things. I am so happy the injury made me skip soccer camp. I had the best summer ever!
- b. (~~↗~~) I would have gone to soccer camp if I had not broken my ankle.

Here, it is not the case that the speaker's failure to break her ankle would preclude an outcome in which she skips soccer camp. Rather, *make* in (16a) sets up a situation that reflects precisely the inevitability relation we have been describing: the injury sets off a chain of causation in which skipping soccer camp moves from a mere possibility to a certainty. Compare this to the use of *cause* in the same scenario. Unlike with *make* in (16a), the established prior possibility of skipping soccer camp clashes with the meaning of *cause* in (17a), resulting in the observed infelicity.

- (17) I usually go to soccer camp in the summer. Last year I was thinking about going to band camp instead, and I could not make up my mind. Then I broke my ankle, which settled things. ?I am so happy the injury caused me to skip soccer camp. I had the best summer ever!

This is precisely the contrast we expect if *make* and *cause* describe different types of causal dependence, and, in particular, if *cause* entails something like the statement of counterfactual necessity in (16b), but *make* does not.

In a parallel scenario, in which the sufficiency of a cause for an effect is explicitly denied (but where necessity remains plausible), we find the reverse pattern of infelicity:

- (18) [Context] A bunch of things happened last summer which led me to skip tennis camp. First, I broke my ankle in the spring, and since

it was taking a long time to heal, I started thinking about band camp for the first time. Then I got into a bad argument with my doubles partner, so even with my ankle getting better, I wasn't sure I wanted to go to tennis. Finally, my parents said they'd get me a new trombone if I went to band camp, which was pretty tempting!

- a. ?I am so happy the injury made me go to band camp. I had the best summer ever!
- b. I am so happy the injury caused me to go to band camp. I had the best summer ever!
- c. (~~↗~~) Breaking my ankle made it inevitable that I would go to band camp.

In the tennis camp scenario above, the use of *make* in (18a) is odd, but the use of *cause* in (18a) is not. This is what we expect, given the failure of (18c), if *make* predicates inevitability of the cause for the effect, but *cause* does not.

2.2.4 Interim conclusion

We propose to capture the 'inevitability' inference associated with *make*-causation in terms of a relation of causal sufficiency, leading to the following hypothesis:

- (19) **Sufficiency hypothesis.** A *make*-causative asserts that its indicated cause was *causally sufficient* for the effect. In other words, given the occurrence of the cause, the occurrence of the effect was guaranteed/inevitable, in a weak sense to be made precise.

We believe this is precisely the type of causation that is indicated in Hume's first definition, where the cause is necessarily followed by the effect. This is a rather natural way for causal dependence to manifest, albeit one that has been neglected in the wake of Lewis (1973; 2000), and related work. In what follows, we attempt to spell out causal sufficiency (and causal necessity) in more explicit terms, and to establish the ways in which these notions differ from the familiar analytic relations of necessity and sufficiency. In addition, we illustrate the ways in which these two types of causal dependence diverge from one another, to produce the types of contrast we have seen emerge between *cause* and *make* in the preceding discussion.

3 Approaching causal necessity and sufficiency

We wish to emphasize that, in our view, the relevant notions of causal necessity and causal sufficiency are not to be identified with the more familiar alethic relations of necessity and sufficiency, nor with metaphysical variants of these relations. Specifically, we do not want to equate causal necessity with counterfactual necessity (*à la* Lewis 1973), nor to equate the ‘inevitability’ associated with causal sufficiency with metaphysical settledness – i.e., truth in all possible courses of events. The challenges associated with defining causation in terms of counterfactual dependence are well known from the philosophical literature (see Menzies 2017; Paul & Hall 2013; Sosa & Tooley 1993, and references therein). These include the problems posed by a range of so-called ‘pre-emption’ scenarios, in which counterfactual dependence fails to hold between two facts or events *C* and *E*, but *C* is nevertheless judged to be a cause (or even *the* cause) of *E*.^{5,6} In a similar vein, defining causal sufficiency in terms of metaphysical settledness would leave us with too strong a notion. For example, when Wendell Potter says in (15) that his visit to the healthcare expedition *made* him leave his job at CIGNA, he is not suggesting that nothing could have happened (in any possible world) after the expedition that could have changed his mind; instead, he is marking out his experience at the expedition as the point at which, given the actual course of events, the question of quitting became settled. In order to capture this, causal sufficiency should be a strictly weaker no-

⁵ One variant of a frequently-discussed pre-emption scenario is as follows:

- (i) Billy and Suzy throw rocks at a bottle. Suzy throws slightly before Billy, so her rock gets there first and shatters the bottle. If Suzy’s throw had not hit the bottle, Billy’s throw would have shattered it, so the bottle would have shattered regardless of Suzy’s action. However, Suzy’s throw is felt to be the cause of the bottle’s shattering, while Billy’s throw is not.

We will not discuss the specifics of pre-emption in this paper, but see Hall (2004); Paul & Hall (2013); Copley & Wolff (2014) for discussion of how causal modeling approaches such as the one adopted in this paper can get around the problems they raise for counterfactual theories of causation.

⁶ One of our aims in this paper is to disentangle causation as a linguistically-relevant concept from the meaning of the lexical item *cause*: we argue, in particular, that there is more than one way in which an event *C* can causally influence another event *E*, and these are described in different ways, and with different natural language resources. However, insofar as we suggest that causal necessity is at least part of what is predicated by English *cause*, our ability to deal with mismatches between intuitively appropriate uses of *cause* and the validity of counterfactual dependence rests on our ability to distinguish between an appropriate notion of causal necessity and counterfactual dependence in its logical sense.

tion than metaphysical settledness, since it requires us to make reference only to a specific subset of all possible futures.

In defining causal necessity and causal sufficiency, then, our first task is to characterize the set of courses of events that is taken into account in interpreting causal claims. Intuitively, these are the courses of events in which the world proceeds ‘as expected,’ based on what is known at evaluation time, both about the state of the world (i.e., what facts are established), and what we know about the (typical) causal consequences of this state. In order to evaluate causative statements, then, we need three things: a context or set of facts about the evaluation world, a means of representing or encoding learned or acquired knowledge about causal relationships in the world, and a mechanism for applying the latter to the former to work out the predictable (causal) consequences. In the Maddow show example, for instance, the ‘settledness’ of Potter’s departure which licenses his use of *make* is a settledness that holds with respect to the state of affairs at the time of the expedition and the unfolding of the causal consequences of this state of affairs.

We call a representation of causal information, both generalized and situation-specific, a **causal model**. For present purposes, we take a causal model to have as its basic components propositions (events) and causal links: it is a network of (one-way) links between proposition, in which a link represents the information that the proposition at which it originates is causally relevant to the proposition it points to, but is not further analyzable. We take this type of network to belong to a language user’s knowledge about the world. In this section, we present an informal sketch of how, given a background context or situation, a set of causal laws, and a means of applying one to the other, we can define causal necessity and causal sufficiency. In this system, the causal relations encoded by lexical items like *cause* and *make* are neither themselves unanalyzable, nor defined in terms of logical relationships, but instead pick out certain structural configurations over a network of (unanalyzable) causal-relevance links; in other words, causal necessity and causal sufficiency (and possibly other lexically-relevant causal dependence relations) are simply concise labels for structural configurations in a complex causal network. The reader interested in a more rigorous presentation than what follows is referred to [Lauer & Nadathur \(2018\)](#), where we describe a formal system for encoding and defining causal dependence configurations, building on the structural equation framework of [Pearl \(2000\)](#), as modified and adapted by [Schulz \(2007; 2011\)](#).

3.1 The circuit example: background situations and causal dynamics

We follow [Schulz \(2007\)](#) in using the [Lifschitz \(1990\)](#) light switch example to illustrate key ideas throughout this section.

(20) **The circuit example.**

- a. Suppose there is a circuit with two switches and one light, such that the light is on (L) exactly when both switches are in the same position (up or not up).
- b. At the moment switch 1 is down, and switch 2 is up.

As presented, the circuit example contains two kinds of information, separated into (20a) and (20b). (20a) sets out certain *causal laws*, a set of cause-and-effect relations that are known to hold between particular facts. (20b) describes a context (in which the laws in (20a) may be relevant) by fixing certain facts about the world. We refer to a specification like (20b) as a **background situation**, and a set of rules like (20a) as a causal **dynamics**.

In reality, no cause acts alone. In all but the most simple cases, any event C which brings about a second event E acts in concert with a set of other events (C_1, \dots, C_n), as well as attending enabling conditions (for example, the failure of a preventative condition P).⁷ In other words, we always evaluate a claim of causal dependence between two events C and E with respect to a background situation that establishes a context of occurrence: a set of facts about the world that are not at issue in the discourse context.

A **situation** can be thought of as a part or partial description of a world:⁸ it fixes some facts about the world, but may leave others unsettled (or undetermined). In a possible worlds framework, a situation therefore corresponds to a set of one or more worlds. For instance, in the circuit example, the situation described in (20b) fixes the position of both light switches, but leaves the state of the light unsettled. This situation might obtain in a world in which the light is on, or in a world in which the switches are in the same position, but the light is off. This situation therefore determines a partial state of affairs, leaving the undetermined fact – the state of the light – as a candidate for at-issue claims.

⁷ See also [Hobbs \(2005\)](#), which develops the notion of a *causal complex*, or the complete set of events and conditions which must obtain in order for a particular result to take place.

⁸ This view of situations is common to otherwise quite different varieties of situation semantics, such as the one proposed in [Barwise & Perry \(1981\)](#) and the one pioneered by [Kratzer \(1989: et seq.\)](#).

3.2 Normal causal developments

Once we fix the facts in (20b), only a world in which the light turns out to be off will accord with the causal laws in (20a). A world in which (20b) is true but the light turns out to be on ‘breaks’ the established dynamics. If we take (20a) to be a complete specification of the relevant causal laws, and also take ourselves to be in a causally-normal world, then the only reasonable expectation is that (20b) will turn out to be part of a larger situation or world in which the light is off. More generally, once we have established that certain causal laws obtain, we expect that events will unfold in a manner that follows these laws. In other words, causal laws tell us what the **normal causal developments** of a given situation will be.⁹ Adding the information that the light is off to (20b) represents a normal causal development of this background situation, but the situation which results from adding the information that the light is on does not. A normal causal development of a situation s is thus a causally-consistent supersituation of s : crucially, it agrees with any valuations in s , and includes facts that follow from these valuations by application of the causal laws. The process of calculating normal causal developments is iterative: having checked for causal consequences of a particular situation s , we can go on to check if the causal laws specify any additional developments, given the facts represented by s and its (immediate) consequences. We will be interested mainly in the *maximal* normal causal developments, i.e. in the normal causal development s' of a situation s which is such that further calculations of causal consequences do not add any facts which are not already included in s' .¹⁰

The laws in (20) are represented graphically in Figure 1. The three nodes, S_1 , S_2 , and L , represent the three propositions that are relevant to example (20); S_1 indicates whether switch 1 is up ($S_1 = 1$) or down ($S_1 = 0$), S_2 whether switch 2 is up or down, and L whether the light is on ($L = 1$) or off ($L = 0$). Arrows represent relations of causal dependence between two propositions; the direction of the arrow indicates the direction of causation. In Figure 1, the states of the switches jointly influence L . The table on the right specifies the causal laws: it tells us what the process of normal causal

⁹ Normal causal developments are closely related to Dowty’s (1979) *inertia worlds*, or the worlds that Kratzer (1981: p. 47) talks about when she writes: “Worlds in which the normal course of events is realized are a complete bore, there are no adventures or surprises.” The difference between the normal causal developments of a situation and inertia worlds is that the former are situations themselves, hence they correspond to a *set* of worlds, and may leave certain facts undetermined.

¹⁰ If the causal laws satisfy certain conditions, the existence of such a *fixed point* of the causal development process is guaranteed, cf. Schulz (2011) and Lauer & Nadathur (2018).

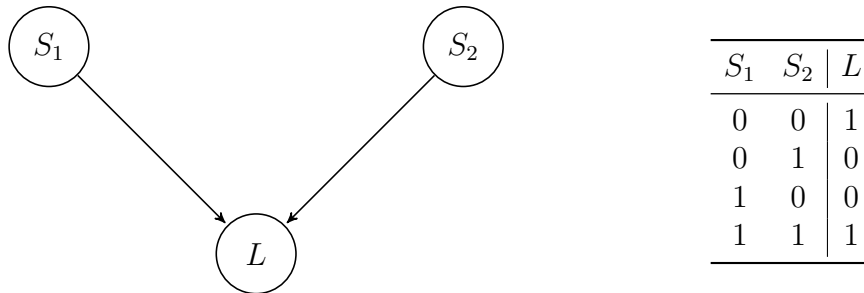

Figure 1: Graphical representation of the circuit example.

development dictates for the state of L , given any combination of valuations for S_1 and S_2 . We will rely on this type of graphical representation through the rest of the paper.¹¹

Returning to situation (20b), the first switch is down, giving us $S_1 = 0$. The second is up, so $S_2 = 1$. L has not been determined. However, from Figure 1, we can read off what the state of the light will be in a normal causal development; given $S_1 = 0$ and $S_2 = 1$, the light should turn out to be off ($L = 0$), as expected.

This is only what happens if everything proceeds *normally*. Various other things might happen under abnormal (or unexpected) circumstances: for instance, someone may have installed a master switch which (in context) assures that the light remains on. That such contingencies are not specified in (20) or Figure 1 reflects the assumption that they represent unusual or unexpected events, which crucially have not been taken into account in the discourse context.

Working with normal causal developments, as established by a causal dynamics, is therefore a species of closed-world reasoning (Reiter 1978). The implicit assumption is that what you see is what you get: the facts represented comprise all of the relevant ones, and what happens in the course of normal causal developments will depend only on this information. Put another way, the normality assumption is equivalent to the assumption that our mental model of a situation is complete and contains all of the relevant information. Inference within a framework of this sort is thus inherently defeasible: if we find that the actual world violates one of the established causal laws, we will conclude not that causality has broken down, but rather

¹¹ The arrows in this graphical representation do not specify the type of causal link encoded, but simply indicate the existence of a dependency, the nature of which is spelled out by the accompanying table (or an equivalent set of structural equations).

that our network must be missing relevant information, and may revise the set of relevant facts (and/or causal laws) accordingly.¹²

3.3 Causal necessity and causal sufficiency

We are now almost ready to define causal necessity and causal sufficiency. Consider a causative statement like (21). In any such statement, regardless of the choice of periphrastic causative, the occurrence of a particular causing event (C) is claimed to be causally responsible for the occurrence of a second event (E).

(21) The storm caused “a historic high tide” to flood the town.

Causative claims like (21) are generally made relative to a particular discourse context, which we can represent with a background situation, or partial specification of facts about the world. In order to evaluate the truth of the asserted causal dependency between C and E , then, we first ‘add’ the fact that C occurred to the background information, and then check the status of E with respect to normal causal developments from the resulting situation.¹³ Before defining particular types of causal relation, then, we need to establish the notion of adding a fact to a situation. For completeness, we also define the notion of subtracting a fact, which will become relevant when we provide lexical entries for *cause* and *make*.

(22) Let s be a situation, and X a proposition.

- a. **Adding a fact to a situation.** Suppose s does not contain a valuation for X . Then $s + (X = x)$, where $x \in \{0, 1\}$, is the supersituation of s which is identical to s , except that it also fixes $X = x$.
- b. **Subtracting a fact from a situation.** Suppose s contains the valuation $X = x$, where $x \in \{0, 1\}$. Then $s \setminus (X = x)$ is the

¹² Some formal systems for representing causal knowledge build this defeasibility in directly, for instance by means of an ‘abnormality’ predicate (e.g., ab ; see Hobbs 2005) – in such a system, if we know A and B typically cause C , we can represent this as $A \wedge B \wedge \neg ab \supset C$; if $A = 0$ and $B = 0$, but $C = 1$, we will conclude that $\neg ab = 0$, and something atypical has occurred.

¹³ Conceptually, this is similar to the type of reasoning we engage in when evaluating the truth of conditional statements according to the ‘Ramsey test’ (Ramsey 1931): roughly speaking, given a statement of the form *If p , then q* , we first ‘add’ p to the established propositions, and then check the status of q .

subsituation of s which is identical to s , except that it does not fix a value for X .

With (22a) in hand, defining causal sufficiency becomes straightforward. In §2.2, we characterized causal sufficiency in terms of the ‘inevitability’ of an effect, given its cause. This amounts to the following: a causing event C is causally sufficient for another event E just in case adding the fact that C occurred to the background situation guarantees that the effect occurs in the course of normal causal developments. Intuitively, we also want to ensure that the effect was not already inevitable prior to the occurrence of the cause; this guarantees that C and E are actually linked in the dynamics – that is, that there is a pathway between them in a graph like the one in Figure 1 (see §3.5 for further explication). This gives us Definition (23).

- (23) **Causal sufficiency** (of one fact for another). Given a dynamics and a background situation s , a fact $C = c$, where $c \in \{0, 1\}$, is **causally sufficient** for a fact $E = e$, where $e \in \{0, 1\}$ iff:
- a. the maximal normal causal development of s does not fix $E = e$
 - b. the maximal normal causal development of $s + (C = c)$ fixes $E = e$

What about causal necessity? In §2.2, we drew a parallel between necessity and certain counterfactual conditional statements, noting that the claim that an event C was causally necessary for another event E is associated with the counterfactual claim that E would not have occurred without C . We want a causal necessity relation, therefore, to stipulate that E was not possible prior to C 's occurrence. Similarly, if there is a third event C' such that adding $C' = 1$ to the background situation produces $E = 1$ in the course of normal causal developments, the augmented situation must (first) guarantee $C = 1$ (or else we would have a route to $E = 1$ without verifying C). This gives us Definition (24).¹⁴

- (24) **Causal necessity** (of one fact for another). Given a dynamics and a background situation s , a fact $C = c$, where $c \in \{0, 1\}$ is **causally necessary** for a fact $E = e$, where $e \in \{0, 1\}$ iff:

¹⁴ (24) is similar in several respects to various conceptualizations of the notion of an ‘actual cause’ that have been proposed in the causal modeling literature on which we build here, e.g. by Pearl (2000); Halpern & Pearl (2005); Halpern (2015). We do not intend it as an alternative to or replacement for these conceptualizations, but only use it here as foil for comparison with the notion of causal sufficiency. It may well be that the semantics of necessity causatives (such as the verb *cause*) is better explicated in terms of one of the definitions of ‘actual cause’, rather than the version of causal necessity defined here.

- a. the maximal normal causal development of s does not fix $E = e$
- b. there is a supersituation s' of $s + (C = c)$ such that s' does not contain $E = e$ and the maximal normal causal development of s' fixes $E = e$.
- c. there is no supersituation s'' of s such that s'' does not contain $E = e$, and the maximal normal causal development of s'' fixes $E = e$, but does not fix $C = c$.

We return to the circuit example to see how (23) and (24) work in practice. Instead of (20b), let us consider a new background situation $s = \{S_1 = 0\}$ which fixes the position of the first switch as down, but leaves the status of the second switch and the light undetermined.

Relative to s , $S_2 = 1$ is causally sufficient for $L = 0$ (i.e., setting the second switch to the up position is causally sufficient for the light to go off). Since, as illustrated by Figure 1, the state of the light depends on the position of both switches, s alone does not fix a value for L in the course of normal causal developments, satisfying (23a). However, if we add the fact $S_2 = 1$ to s , we get a new situation $s' = s + (S_2 = 1)$ which fixes $L = 0$ in its (first) normal causal development. This satisfies (23b).

Against the background situation $s = \{S_1 = 0\}$, it turns out that $S_2 = 1$ is also causally necessary for $L = 0$ (turning the second switch to the up position is causally necessary for the light to go off). We have already seen that (24a) is satisfied. (24b) is satisfied because $s' = s + (S_2 = 1)$ is causally sufficient for $L = 0$ and s' is trivially a supersituation of itself. Finally, (24c) is satisfied because the only supersituation of s whose normal causal developments fix $L = 0$ is the situation s' , which fixes $S_2 = 1$.

In defining a lexical semantics for *make* (and *cause*) along the lines set out in §2.2, causal sufficiency and causal necessity are the central notions required. We have defined these relations in terms of the three components listed at the beginning of this section: a background situation, a causal dynamics, and a notion of normal causal developments (that is, a method for calculating how a situation is expected to evolve with respect to a specification of causal laws). These components can be formalized in different ways, associated with different modeling choices (Hitchcock 2010; Kistler 2006; Pearl 2000; Talmy 1988; Walsh & Sloman 2004; Wolff 2007; Woodward 2003; among others). In Lauer & Nadathur (2018), we draw on the deterministic framework of Schulz (2011), which builds on Pearl (2000). This choice has certain consequences for how we define causal sufficiency and causal necessity, and these are reflected in the informal discussion in this paper.

At this time, we are not aware of significant differences that follow from the choice of an alternative underlying model. However, insofar as formalizing the components of causal dependency relations in different frameworks leads to different empirical predictions (about the appropriate use of *make*, *cause*, or other causative lexical items), we would like to suggest that these predictions will ultimately permit adjudication between frameworks. Consequently, although we do not engage in such comparisons here, comparing the predictions made as a result of different formal modeling choices will allow us to develop a more accurate picture of the structure and organization of our linguistic and cognitive conceptions of causation in the world.

3.4 Lexical entries for *make* and *cause*

Our top-level claim in this paper is that more than one kind of causal bringing-about relation is represented in the lexical meaning of causal and causative language. To illustrate this claim, we focus on the specific claim that *cause* and *make* each carry a bringing-about component that the other does not. More specifically still, we propose that *make* predicates causal sufficiency, while *cause* does not; we suggest additionally that *cause* carries a causal necessity entailment which *make* does not share.

There is a significant body of work in both linguistics and philosophy that deals with the precise meaning of the lexical item *cause*. Much of this literature argues that *cause* entails more than a necessity claim (counterfactual or otherwise), cashing out this additional meaning with varying degrees of complexity. While we are sympathetic to the basic premise that *cause* entails more than just causal necessity, we will not weigh in on the nature of any additional lexical components here (for instance, on the relevance or encoding of a ‘tightness’ or ‘directness’ requirement; Cruse 1972; Shibatani 1976; McCawley 1978; Levin & Rappaport Hovav 1994; Wolff 2003). Instead, for the remainder of the paper, we will focus on the causal necessity requirement of *cause*, in contrast with the causal sufficiency requirement of *make*. The toy examples presented illustrate the crucial necessity/sufficiency distinction, and thus we do not think it is necessary at this juncture to fully explore any additional components of *cause*. In a broader sense, all we wish to commit to, with respect to the lexical semantics of *cause*, is that it predicates at least a relation of causal necessity between cause and effect.

With this in mind, we let $[\cdot]$ represent the semantic interpretation function. We assume that $[\cdot]$ takes two contextual parameters: a dynamics D and a background situation s which partially specifies the evaluation world

w_e . This reflects the fact that what we know, both about the state of the world, and about any causal laws which it obeys, is information that is built up contextually, and which can vary from one discourse context to another. We further assume, following Lewis (1973), that causatives at base express relations between two facts or events. When the subject argument of a periphrastic causative statement is an entity or individual, we take this to stand in for some event in which the individual was a participant. We call this event C , and represent the fact of its occurrence by $C = 1$ (thus, in (25), either $X = C$ or X is a participant in C). The effect E is represented by the composition of a causee/object NP and a VP complement: $E = \llbracket \text{VP} \rrbracket (\llbracket Y \rrbracket)$, below. We propose the following semantics for *make* and *cause*:^{15,16}

- (25) Given a background situation $s \subseteq w_e$, and a dynamics D , let $s' = s \setminus (C = 1)$ if s contains the occurrence of C ; else let $s' = s$.
- a. $\llbracket X \text{ make } Y \text{ VP} \rrbracket^{D,s} = 1$ iff $C = 1$ is causally sufficient for $E = \llbracket \text{VP} \rrbracket (\llbracket Y \rrbracket)$ relative to s' , and $w_e(C) = 1$.
 - b. $\llbracket X \text{ cause } Y \text{ to VP} \rrbracket^{D,s} = 1$ iff $C = 1$ is causally necessary for $E = \llbracket \text{VP} \rrbracket (\llbracket Y \rrbracket)$ relative to s' , and $w_e(C) = w_e(E) = 1$.

For the Lifschitz example, given the background situation $s = \{S_1 = 0\}$, we showed that $S_2 = 1$ was both causally sufficient and causally necessary for $L = 0$. Taken together with the lexical entries in (25), this makes the

¹⁵ The definitions for *make* and *cause* are not entirely parallel, in that *cause* is taken to require not only the occurrence of the cause, but also the occurrence of the effect. *Make* requires only the occurrence of the cause; the occurrence of the effect follows from this, coupled with the definition of causal sufficiency.

¹⁶ While *cause* can be grammatically used with only an NP complement, *make* requires both an NP and a VP. The following examples were suggested by a reviewer.

- (i)
 - a. The food shortage caused the riot.
 - b. ?The food shortage made the riot.

While it is possible that this syntactic difference reflects a semantic difference in what types of objects (individuals and events) can be treated as *cause* vs. *make* effects, our intuition is that (ia) is semantically equivalent to (iia), while (ib) is improved by the addition of a VP:

- (ii)
 - a. The food shortage caused the riot to happen.
 - b. The food shortage made the riot happen

We believe that the close comparison between those examples and the examples in (ii) justify the assumption that the causal relationships predicated by causative verbs hold between events: we take the object NP in (ia) to be eventive. Thus, for simplicity of presentation, we have chosen to treat both *cause* and *make* in (25) as three-place predicates; the judgements and contrasts in this paper deal with examples having the structures in (ii).

empirical prediction that (26a) and (26b) are both felicitous and true in a situation where what we know is that the first switch is down.

- (26) a. Turning the second switch on makes the light go off.
 b. Turning the second switch on causes the light to go off.

The prediction, according to our intuition, is upheld.

3.5 Constraints on background situations

Not every partial specification of a state of affairs constitutes a reasonable background situation against which to evaluate causative claims. In this section, we examine some natural constraints on background situations, at the level of descriptive generalization. Ultimately, we would like a complete formal account to predict these constraints, as consequences of the structure of causal dependency relations, separate lexical presuppositions of causative verbs, or some combination thereof.

In fact, definitions (23) and (24) already incorporate constraints on the background, which serve to preclude vacuously true or false claims of causal dependence. The first constraint actually appears in (22) (which feeds (23) and (24)): since, for any situation s and (causing) fact $C = 1$, the augmented situation $s + (C = 1)$ is defined only if s does not fix a value for C , the background situation for claims of causal necessity and causal sufficiency cannot contain either the causing fact or its negation. This is reflected in the lexical entries for *make* and *cause*, where we first subtract the causing event from the background situation before evaluating the causal claim. Intuitively, this is because evaluation of a causative requires us to – in some sense – isolate the cause from the remainder of the background situation before examining its relationship to its purported effect.

Definitions (23) and (24) also prohibit background situations which contain the caused fact $E = 1$, or guarantee it in the course of normal causal developments. This constraint appears as clause (a) of both definitions (23) and (24). Omitting this clause leads to vacuously true causal sufficiency claims: for instance, where a fact $C = c$ can be found to be sufficient for $E = e$ even if the dynamics does not encode any causal pathway between C and E . Conversely, omitting (24a) produces vacuously false causal necessity claims, since, if the background situation s guarantees $E = e$, then clauses (24b) and (24c) are not mutually satisfiable.

We lump these two constraints together in (27):

- (27) **Constraints against vacuous causative claims.** In the evaluation of a causative claim involving causing fact $C = c$ and caused fact $E = e$, the background situation:
- a. cannot contain either $C = c$ or its negation
 - b. cannot guarantee $E = e$

We now turn to an important constraint which is not already encoded in our definitions. This pertains to the temporal order of the events relevant for the assessment of a causative claim. For simplicity, we focus here on punctual events.

- (28) **Temporal location constraint.** In the evaluation of a causative claim involving causing fact $C = 1$ and caused fact $E = 1$, the background situation can fix only those facts that are settled at the evaluation time of the causative claim. By default, the evaluation time is the time at which C is determined.

We will see this constraint at work below, in §3.6.3. Here, we note only its plausibility. Since causes, as far as we know, do not follow their effects, claims about the causal dependence of an event E on another event C should not take for granted facts that were not settled at the time that the causing event occurred (though they may have been settled by the discourse time). This is because they might, at the time that the purported causal chain was set into motion, still have turned out differently. Put another way, causative claims involve causal bringing-about relations: the question of whether or not C causally influenced E rests entirely on the consequences of C , combined with any facts that were settled in the temporal run-up to C 's occurrence time.

We will be concerned with one further constraint on background situations, which deals specifically with propositions encoding information about an agent's desire or intention to perform specific actions. This constraint becomes relevant only in the context of *make*'s 'coercive' implication, however, and we therefore discuss both in §4.1.

3.6 Illustrating the account

In this section, we examine a few scenarios. These examples are constructed in order to tease apart the causal bringing-about relations of necessity and sufficiency, as defined above. We show that our account, on which causative *make* predicates causal sufficiency but not causal necessity, and *cause* the reverse, makes the correct empirical predictions in these cases.

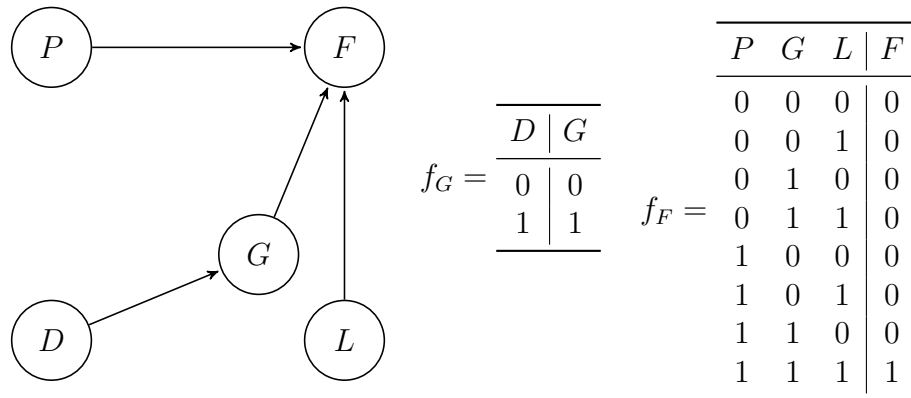

Figure 2: Dynamics for the fire scenario. P = whether or not power was restored to the line, D = whether or not there were drought conditions, G = whether or not the grass was inflammable, L = whether or not the power line was downed, and F = whether or not the field caught fire. .

In §3.3, we illustrated the proposed definitions for *make* and *cause* using the Lifschitz example; in particular, we showed that, given a background scenario in which the first switch is known to be down, turning the second switch to the up position is both causally necessary and causally sufficient for the light to go off. This accords with our intuitions about the pair of sentences in (26), repeated here for ease of reference: if the first switch is down, both (29a) and (29b) are felicitous descriptions of the (causal) state of affairs.

- (29) a. Turning the second switch on makes the light go off.
 b. Turning the second switch on causes the light to go off.

The Lifschitz example has been useful in illustrating how a simple dynamics works, but the scenario referenced above does not allow us to check for the proposed distinction between *cause* and *make*. In order to do so, we need to consider scenarios in which the causal dynamics are more complex. The next scenarios allows us to tease causal sufficiency and causal necessity apart.

3.6.1 A necessary, but insufficient cause: the fire scenario

We first consider a relatively simple situation that illustrates the difference between *cause* and *make* in case of a necessary but insufficient cause. The fire scenario is represented as a dynamics in Figure 2.

- (30) **The fire scenario.** A fire burned a field outside town, starting immediately after the electric company restored power to a line that ran through the field, and which had previously been shut off. Due to a long drought, the grass in the field was unusually dry, and thus more susceptible to burning than usual. In general, a power line can spark a fire only if electricity is flowing and the comes into contact with something grounded and inflammable – for instance, dry grass. Unfortunately, there had not been an inspection of the area for several months, and so the condition of the line (i.e. whether or not it was downed) is unknown, and cannot be determined by direct evidence in the aftermath of the fire.¹⁷

In this situation, we have the following intuitions about *cause* and *make*:

- (31) a. #Restoring power made the field catch fire.
 b. Restoring power caused the field to catch fire.

In evaluating these claims, the relevant background situation contains the drought conditions and consequent inflammability of the grass, $s_b = \{D = 1, G = 1\}$. Against this background, we can show that the power restoration was a necessary but insufficient condition for the fire to start.

Causally speaking, s_b is a stable situation: it is its own maximal normal causal development. This is easy to see from Figure 2: G is the only direct causal descendant of D , and F the only descendant of G . G is already fixed by s_b , and F cannot be determined in the absence of values for P and L . Nothing much changes when we augment s_b with $P = 1$, $s' = \{D = 1, G = 1, P = 1\}$. Since we still have no value for L , we cannot determine F , and P has no other descendants. This violates condition (b) for causal sufficiency, and, relative to s_b , $P = 1$ is not sufficient for $F = 1$.

Relative to s_b , however, $P = 1$ is causally necessary for $F = 1$. We have already seen that s_b cannot fix a value for F in its maximal normal causal development; this satisfies condition (a) for necessity. We need to check conditions (b) and (c). For (b), the supersituation of $s' = \{D = 1, G = 1, P =$

¹⁷ If we assume that the fire required all and only these conditions to start, then knowledge of the fire allows us to infer that the power line must have been downed at some point when electricity was flowing through the line. As noted previously, we typically use *cause* when we are aware that a number of conditions came together to produce a particular effect, but cannot necessarily enumerate or establish the values of all of them; inferring that all (other) relevant necessary conditions were met is part of what ‘comes along’ with a *cause* statement. Given a closely circumscribed situation like the one in (30), it seems a bit artificial to treat the value of the proposition L as ‘unknowable’; we enforce this here to illustrate the conditions under which causal necessity claims can be felicitously made.

1} which ensures $F = 1$ is the proper supersituation s'' which contains, additionally, $L = 1$. Then s'' contains the three facts $G = 1, P = 1$ and $L = 1$, and its first normal causal development (which is also its maximal development) fixes $F = 1$. Condition (c) is also straightforward: given a situation s which does not contain $F = 1$, the only way this fact can follow in the course of normal causal developments of s is if s contains values for P, G , and L (specifically, if s values all three propositions at 1). Since P has no causal ancestors, there is no way we can omit P from a situation s and still ensure the fire as a causal consequence of s . Thus, the only 'route' to $F = 1$ must pass through $P = 1$, and the restoration of power is a causally necessary condition for the fire.

Thus, if *cause* predicates causal necessity, and *make* causal sufficiency, we predict that *cause* should be appropriate in the fire scenario (30), while *make* should not. These are precisely the intuitions reported in (31).

Suppose now that we alter the fire scenario slightly as follows: the day before the fire, a resident of the town had walked through the field, and observed that one post in the power line was down, bringing the line into contact with the ground. She shared this information with inspectors in the aftermath of the fire. In this case, our background situation s_{b_1} contains the fact $L = 1$, indicating that the power line was downed, as well as $D = 1$ and $G = 1$, as before. Against this modified background situation, $P = 1$ is both causally necessary and causally sufficient for the fire (the proof runs entirely parallel to the Lifschitz example). Given the additional information about the condition of the line, both (31a) and (31b) seem felicitous, as predicted by our account.

3.6.2 A sufficient but unnecessary condition: the bus scenario

We next consider a scenario involving a sufficient, but unnecessary cause. The bus scenario is represented as a dynamics in Figure 3.

- (32) **The bus scenario.** Lia has a high-end triathlon bike, which she rides to work almost every day. She takes the bus when rain is predicted for the evening, because it gets too cold to bike home in the rain. Occasionally, Lia's friend Ava visits her. Ava is a pro cyclist. She gets up early and borrows Lia's bike for training when she has a race coming up.
At the moment, Ava is visiting. She has a race coming up in two weeks, and is in the middle of training. Rain is predicted for the evening.

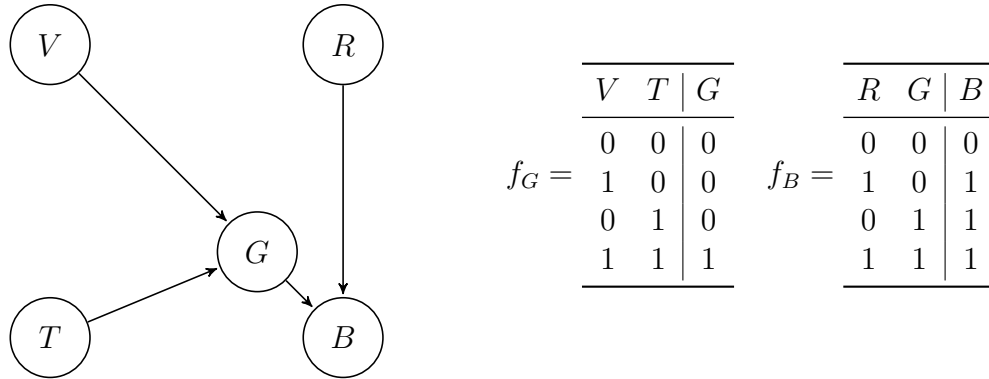

Figure 3: Dynamics for the bus scenario. V = whether or not Ava is visiting, T = whether or not Ava is training for a race, G = whether the bike is gone or not, R = whether or not rain is forecast, B = whether or not Lia takes the bus to work. .

In this situation, we have the following intuitions:

- (33) a. Ava's training made Lia take the bus to work.
 b. #Ava's training caused Lia to take the bus to work.

We consider the background scenario $s_b = \{V = 1, R = 1\}$. In this context, $T = 1$ is sufficient but unnecessary for $B = 1$.

The background situation s_b has no causal consequences. G is the only descendant of V , but its value cannot be determined without a value for T . B is a direct descendant of R , but since B is influenced by both G and R , B cannot be determined without a value for G . This satisfies condition (a) for causal sufficiency. Augmenting s_b with $T = 1$ gives us the situation $s' = \{V = 1, R = 1, T = 1\}$. In this case, the first normal causal development fixes $G = 1$. Since the background contains $R = 1$, the second normal causal development fixes $B = 1$. This satisfies condition (b).

Relative to s_b , $T = 1$ is not necessary for $B = 1$, because s_b cannot satisfy condition (c). The situation $s'' = \{V = 1, R = 1, G = 0\}$ fixes $B = 1$ in its first causal development, and does not contain $T = 1$.

Since $T = 1$ is sufficient but unnecessary for $B = 1$ in this scenario, our account predicts the judgements in (33).

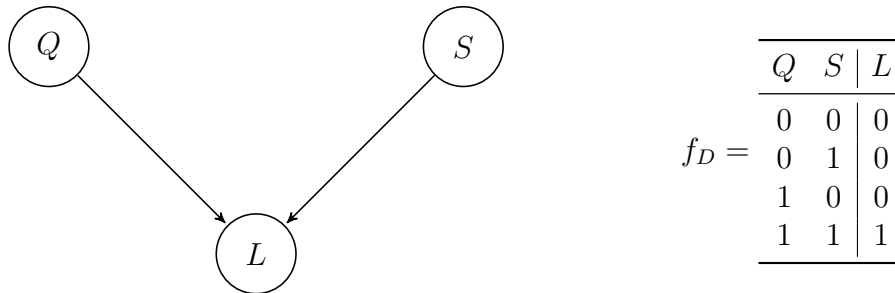

Figure 4: Dynamics for the lighthouse scenario. Q = whether the earthquake happens, S = whether the storms happen, L = whether the lighthouse collapses..

3.6.3 The temporal constraint: the lighthouse scenario

Finally, we consider a simple scenario that illustrates the role of the temporal constraint. The lighthouse scenario is represented as a dynamics in Figure 4.

- (34) **The lighthouse scenario.** The lighthouse was built with a very sturdy foundation, designed to withstand high winds at the tower top, but the foundation sustained structural damage in an earthquake about ten years ago. Even that would have been fine, but this year, there were record-setting winds and the worst hurricane season anyone can remember, and given the prior damage, it could not take the extra strain.

The intuitive judgements for the possible *cause* and *make* claims in this scenario are as follows:

- (35) a. The earthquake caused the tower to collapse.
 b. The storms caused the tower to collapse.
 c. #The earthquake made the tower collapse.
 d. The storms made the tower collapse.

In order for our account to capture the empirical judgements in (35a) and (35b), it must be the case that both the earthquake and the storms represent necessary causes for the collapse. To capture the judgements in (35c) and (35d), the storm must be a sufficient cause, while the earthquake is not. As we show below, these are precisely the dependence relations encoded in Figure 4.

First, relative to the empty situation s_\emptyset , both $E = 1$ and $S = 1$ are clearly necessary for $L = 1$. This explains the judgements in (35a,b). Second, relative to the situation s_E which fixes that the earthquake happened, $S = 1$ is sufficient for $L = 1$. Since s_E abides by all our constraints, we account for the judgement in (35d).

But there is no situation obeying our constraints relative to which $E = 1$ is sufficient for $L = 1$. The only such situation would be s_S , which determines that the storm happens. But, in the evaluation of (35c), s_S is not a valid background situation: it fixes the storm, which happens after the earthquake, hence it violates the **temporal location** constraint. Hence we also explain the judgement in (35c).

Things are similar in the sports camp scenarios, repeated here for convenience:

- (36) I usually go to soccer camp in the summer. Last year I was thinking about going to band camp instead, and I could not make up my mind. Then I broke my ankle, which settled things.
- a. I am so happy the injury made me skip soccer camp. I had the best summer ever!
 - b. ??I am happy the injury caused me to skip soccer camp. I had the best summer ever!

In the variant in (36), clearly, the injury is a sufficient cause: a situation that contains the injury will normally develop into one in which the speaker skips soccer camp. But it is not a necessary cause, since the speaker might have decided not to go to soccer camp even without the injury.

The tennis camp example inverts the situation:

- (37) A bunch of things happened last summer which led me to skip tennis camp. First, I broke my ankle in the spring, and since it was taking a long time to heal, I started thinking about band camp for the first time. Then I got into a bad argument with my doubles partner, so even with my ankle getting better, I wasn't sure I wanted to go to tennis. Finally, my parents said they'd get me a new trombone if I went to band camp, which was pretty tempting!
- a. ?I am so happy the injury made me go to band camp. I had the best summer ever!
 - b. I am so happy the injury caused me to go to band camp. I had the best summer ever!

In this variant, the ankle injury led to the speaker skipping tennis camp only in concert with other factors, which occurred later (the fight, the parents' offer of a new trombone). Hence, these contingencies cannot be fixed by the background situation for (37a), and the ankle injury cannot count as sufficient for going to band camp.

At the same time, while the scenario does not specify this, it is entirely possible that the fight and the offer alone would not have been enough for the speaker to go to band camp instead of tennis camp. In this case, the injury would be a necessary (contributing) cause for the speaker to go to band camp, licensing the *cause* in (37b).

4 Deriving the implications of causative *make*

In §2.1, we observed that replacing *cause* with *make* in a causative claim produces a range of rather specific implications. We showed, however, that none of these putative implications could be entailments of a univocal causative *make*, since, for each of the implications, we readily find examples where it is absent.

A successful analysis of *make* must nonetheless provide the resources to derive these implications if and when they arise. A positive consequence of the sufficiency hypothesis in (19) is a resolution to this problem. Since *make* and *cause*, on our view, assert different causal relations, we can in principle explain any particular inference as the outcome of pragmatic reasoning associated with the specific lexical content of the verb in question. In this section, we focus on two implications of *make*, both of which arise with some generality, and show how they can be derived on our analysis.

4.1 The coercive implication

Consider the following examples, repeated from §2, both of which feature VPs representing volitional actions:

- (2e) ...I ...made [our dog] walk through an area of bush ...
 (10a) [Anand's mother] ...made Anand pump the tires [of the bicycle] every morning.

Both of these examples suggest resistance from the causee: that is, that the causee was unwilling to bring about the effect. We will call this inference

the **coercive implication** of *make*, after Shibatani (1976), who refers to causal descriptions like (2e) and (10a) as instances of ‘coercive causation’.

- (38) **The coercive implication** (version 1):
NP_S made NP_O VP implies that $\llbracket NP_O \rrbracket$ did not want to $\llbracket VP \rrbracket$

As we saw earlier, (38) cannot be an entailment of a univocal causative *make*, because it does not arise across the board: recall examples like (3a), which feature VPs that are presumably desirable to the causee.

- (3a) I was scared, but they made me feel confident.

However, we believe that the inference of resistance or unwillingness in examples (2e) and (10a) arises as a consequence of a less specific implication, which is generally valid. To elucidate this, we return to our original *make* causative:

- (1b) Gurung made the children dance.

We do indeed tend to infer from (1b) that the children did not want to dance: the same inference does not arise if we replace *make* with *cause* or *get*, as in examples (1a) and (1d). Certainly (1b) is felicitously used to describe a situation in which Gurung overruled the children’s wishes in bringing about the dancing event (for instance, by threatening them with punishment). On closer consideration, however, (1b) could also be used to describe a situation where the children were in fact willing to dance, as long as the following is also true: whatever Gurung did would have brought about the dancing, even if they did not want to do it. Such a context might be one in which Gurung enjoys complete authority over the children, so that they have no choice but to obey an order from him. Consequently, they dance when he tells them to. (1b) is an entirely reasonable description of this situation, even if it also happens to be the case that the children were eager to dance. This suggests that what the choice of *make* in (1b) implies (by contrast to alternative periphrastic causatives) is not that the children were unwilling to dance, but rather that, given Gurung’s action, *whether or not they wanted to dance had no effect on the outcome*.

We believe that inferences about coercive causation are captured by the following descriptive generalization:

- (39) **The coercive implication of *make*** (final version):
 If $\llbracket VP \rrbracket$ is a volitional action, then *NP_S made NP_O VP* implies that $\llbracket NP_O \rrbracket$ did not make a free decision to $\llbracket VP \rrbracket$.

Here, if an agent makes a ‘free decision’, it means that they had a real option to do otherwise: that is, that they might have brought about a change in the effect by exercising their will. Our analysis predicts (39): a *make* which predicates causal sufficiency is well-suited to explain the source of a (weak) coercive implication of this sort. Intuitively, if (1b) describes a situation in which Gurung did something that was sufficient to bring about the dancing event, then the children could not have made a free decision to dance. If they had, then they might have avoided dancing by changing their minds: in other words, there would be a possible sequence of events in which Gurung’s action occurs and the causal laws are upheld, but no dancing takes place. But then, by definition, Gurung’s action did not make the dancing inevitable. Thus, the absence of a free decision about volitional effects seems to follow naturally on an analysis of *make* as a sufficiency causative.

To see how this intuitive explanation can be cashed out, we need to look more closely at what it means for a causing event to be sufficient for a volitional action in a dynamics. Intuitively, volitional actions are ones for which the intentions or desires of the agent (the causee, for present purposes) are relevant: volitionality has to do with the potential influence of an agent’s intentions upon an event’s realization. We therefore associate any volitional event V in a dynamics with a proposition W_V which encodes whether or not the (potential) agent of V wants V to come about. On this picture, the question of coercion then rests on the relationship between W_V , V , and the cause C associated with V by a *make* statement.¹⁸

In order to fully capture the coercive implication, and thus to predict the behaviour of *make*, we will need to constrain this relationship. The following example illustrates why.

- (40) *Context:* The children have been eager to dance all afternoon, looking forward to their dance lesson. Gurung is their (strict) instructor, and they are only allowed to dance if he gives his explicit permission. A few minutes into their lesson, he finally tells them they can dance, and they do so happily.

¹⁸ There are, of course, certain kinds of actions which can be volitional or involuntary: one example would be laughing. In our view, a dynamics would capture this distinction by encoding whether or not a proposition standing for the agent’s intentions is causally relevant (with respect to a background situation) for the determination of the effect, or whether external forces – tickling, exposure to a very funny joke – rendered the causee’s preferences in the matter immaterial, or bypassed them altogether. Truly involuntary actions such as blushing or starting, for instance, would not be causally linked to a proposition representing the agent’s intentions at all.

- a. ??Gurung made the children dance.
 b. $\not\rightarrow$ The children did not make a free decision to dance.

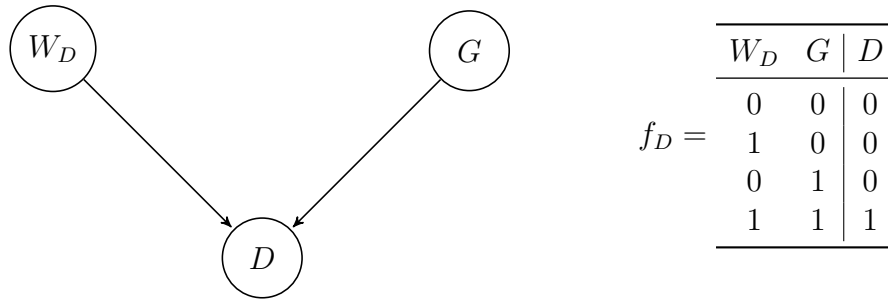

Figure 5: Dynamics for the permission scenario. W_D = whether or not the children want to dance, G = whether or not Gurung gives permission for them to dance, D = whether or not the children dance.

The permission context in (40) is modeled in Figure 5. The relevant causal laws specify that dancing follows only from the conjunction of the children’s desire to dance ($W_D = 1$) and Gurung’s explicit permission ($G = 1$). Since the background situation in (40) fixes the children’s will in the positive direction, Gurung’s action satisfies the requirements for causal sufficiency. According to the current analysis, then, *make* should be licensed. This contradicts the empirical judgement in (40a); our intuition is that this judgement is because (40) does not license the coercive implication. Gurung’s permission, while sufficient for bringing about dancing in view of the children’s pre-existing desires, does not eliminate the possibility of a free decision. Given the dynamics, the children could change their minds and consequently refrain from dancing, Gurung’s actions notwithstanding.

One way to rule out contexts like (40) would be to require that a background situation for *make* does not fix the value of a will/desire proposition for the effect. Insofar as this requires leaving intentions as an open issue, it seems to get at the ability of agents to change their minds. In the absence of a background valuation for W_D in (40), Gurung’s permission will not be sufficient to bring about the dancing, as per definition (23). However, there are felicitous uses of *make* which clearly fix the intentions of a causee as part of the background: moreover, these examples include ‘prototypical’ uses of *make* with a volitional VP. (41) satisfies not only the weak version of the coercive implication in (39), but also the stronger form in (38).

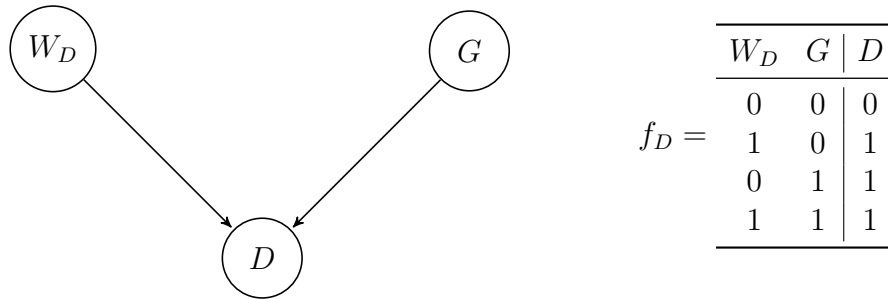

Figure 6: Dynamics for the command scenarios. W_D = whether or not the children want to dance, G = whether Gurung commands them to dance, D = whether or not the children dance.

- (41) *Context:* The children are tired from a long day, and are not looking forward to dancing in their dance lesson. Gurung is their strict instructor, and they are required to obey any commands he gives them. As soon as they arrive in class, he tells them to dance. They start dancing.
- a. Gurung made the children dance.
 - b. \rightsquigarrow The children did not make a free decision to dance.
(\rightsquigarrow The children were unwilling to dance.)

Make is acceptable in the command scenario, even though the background fixes the children's desire with respect to dancing ($W_D = 0$). We certainly do not want to rule out the use of *make* in this type of context, so it cannot be the case that *make* does not admit background situations which fix desire predicates. Moreover, changing the constraint so that it only precludes background situations which fix desire propositions in a result-conducive direction will not solve the problem: this would fail to capture the judgement in (42), which represents precisely the type of context that a weak coercive implication like (39) is intended to cover.

- (42) *Context:* The children have been feeling eager to dance all afternoon, looking forward to their dance lesson. Gurung is their strict instructor, and they are required to obey any commands he gives them. As soon as they arrive in class, he tells them to dance. They immediately start dancing.
- a. Gurung made the children dance.
 - b. \rightsquigarrow The children did not make a free decision to dance.

In (42), Gurung's command is coercive not because it produces an outcome at odds with the children's established will, but instead because it renders their desires irrelevant to the question of dancing. This is what we would like to capture: the agent/causee's intentions should not be able to make the outcome for a volitional action in a dynamics, *if we take it for granted that the cause occurs*.¹⁹

This leads us to the following constraint:

- (43) **Constraint on volitional action.** In the evaluation of a *make*-causative involving background situation s , causing event C , and caused event E , no proposition W_E representing the agent's intention to perform E can be such that $W_E = 0$ is sufficient for $E = 0$ relative to $s + (C = 1)$ and also determined by $s \setminus (C = 1)$.

(43) rules out permission scenarios like (40). Since $W_D = 0$ is sufficient for $D = 0$ in the presence of the cause (Gurung's permission), *make* requires that W_D cannot be fixed in the background. On the other hand, $\neg W_D$ is not sufficient for $\neg D$, relative to $s + (G = 1)$, in either of the command scenarios (which have the same dynamics, shown in Figure 6, and differ only in terms of the background setting of W_D); thus *make* can be evaluated in contexts where W_D is determined.

The constraint in (43) also allows us to capture the coercive implication for a third type of scenario, in which the *make*-cause is sufficient for the *make*-effect because of its consequences for the intentions of the agent/causee. These kinds of contexts included cases of persuasion or bribery, as in (44), where Gurung brings about the dancing by making it so that the children cannot but want to dance. Crucially, his action in this case precludes the possibility that they will change their minds.

- (44) *Context:* The only time that the children ever want to dance is when they hear their favourite song, which is so catchy that they cannot resist dancing. They are sitting quietly in class when their instructor Gurung puts on this song. As soon as they recognize it, the children get up and dance.
- a. Gurung made the children dance (by playing their favourite song).
 - b. \rightsquigarrow The children did not make a free decision to dance.

¹⁹ As noted earlier, cases where there is no causal pathway in the dynamics between an agent's intentions and the effect do not, for our purposes, count as volitional actions.

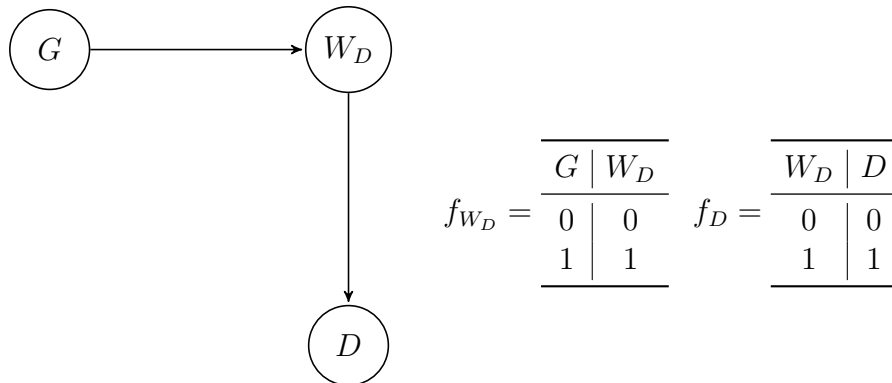

Figure 7: Dynamics for the persuasion scenario. W_D = whether or not the children want to dance, G = whether Gurung plays their favourite song, D = whether or not the children dance.

In the persuasion context, $W_D = 0$ is sufficient for $D = 0$ (in both the presence and absence of the cause); thus we require that W_D is not fixed by the background situation. This allows us to capture not only the judgement in (44a), but also the fact that, in persuasion contexts of this sort, the intentions of the agent depend upon the presence of external factors (and thus, intuitively, if the causal laws are obeyed, should not be determined in the absence of a determination for their causal ancestors).

A more complex persuasion example²⁰ comes from the naturally-occurring case of the social smoker in (45).

- (45) I have freaking awesome friends. freaking awesome. But some of them make me smoke too much.

Here, the author is not claiming that her friends physically force her to smoke (thus making her own intentions irrelevant). Instead, her claim is that the presence of her friends (and/or their actions), *viz.* their smoking), together with attendant circumstances, such as the author's presumed addiction to nicotine, and habits she has consequently formed, create in her a desire to smoke when she is in the presence of her friends. Consequently, her friend's presence is sufficient to bring about smoking. The Maddow show example, (15), is similar: Potter does not claim that his experience at the healthcare expedition directly led him to quit his job, but rather that it fixed his opinions/intentions about the matter in such a way that quitting became inevitable. A positive consequence of the volitional constraint

²⁰ This example was originally retrieved as a status message on a social networking website.

as formulated, then, is that it captures not only the prototypical ‘coercive’ scenarios, but also the weaker sense of coercion that applies in persuasion situations.

Compared to the constraints discussed in §3.5, the volitional action constraint is much more limited in its applicability. As stated, this constraint is only relevant for *make*-causatives. Essentially, (43) represents a lexical presupposition of *make*. We see this as an improvement over attempts to encode a coercive implication, as per Shibatani or (38), into the entailments of *make*. The volitional constraint produces the coercive implication as a consequence of restrictions on the structure of background situations: we avoid referring directly to the volitionality of an effect in the meaning of *make*, while still producing the coercive implication *just in case* a volitional action is involved. *Make* constructions without volitional effects will automatically satisfy the requirements of (43).

The volitional constraint appears rather natural once we consider that sensitivity to questions of desire/intention appears to be a feature of the English causative system. If we compare (1b) with (46), in which *make* has been replaced by *let*, we find that (46) is appropriate in precisely those contexts in which the volitional constraint rules *make* out; the reverse is also true.

(46) Gurung let the children dance.

More specifically, *let* is appropriate in the permission scenario (40), where *make* is not, but is not appropriate in the command or persuasion scenarios, where *make* is felicitous. This suggests that *let* – which, like *make*, can also occur in a range of contexts involving non-volitional effects – is also a sufficiency causative, but carries a presupposition (in the form of a constraint on background situations) that is complementary to (43). Extrapolating farther, if this type of constraint is a peculiarity of the English causative system, then we might reasonably expect that sufficiency causatives in other languages show different types of background restrictions. One particularly interesting case comes from German causative *lassen*, which can be used to paraphrase both *let* and *make* statements in English, and would be appropriately used in all three types of contexts discussed above (permission, command, and persuasion). We pursue an analysis of *lassen* as a sufficiency causative lacking a coercive implication in Lauer & Nadathur (2018).²¹

²¹ The full range of potential sufficiency causatives in English plausibly includes not only *make* and *let*, but also *force* and perhaps even *enable*, all of which seem sensitive to questions of causee volition. Capturing the distinctions between these verbs may require a more

We would like to raise one final point in the discussion of *make*'s coercive implication. In addition to prototypically volitional actions, such as dancing, and prototypically involuntary actions, such as blushing or turning red, *make* can also appear with actions that are in some cases volitional and others involuntary. In the examples in (47), *make* is felicitous due to the inherently involuntary nature of the result.

- (47) a. ?Mooen Ali has described an incident that made him turn red in the cricketing field.
 b. ?She has suffered from hyperthyroidism for many years and the disease made her feel dizzy and uneasy even before the disaster.

As we have noted, *make* is also felicitous in cases where the effect might (in some slight variation of the given context) have been brought about due to the causee's volition, but where the cause was ultimately sufficient for the effect because it overruled the causee's will. Since our understanding of the background possibilities are different in these configurations, we get a stronger coercive implication in command cases than we do in fully involuntary cases like (47). What we wish to emphasize is that a view of the coercive implication based on the descriptive generalization (39) and the attendant volitional constraint (43) allows us to capture this relatively subtle distinction, while seeing how command-type coercion is, causally speaking, similar to cases where a result is produced involuntarily. The baseline commonality between both involuntary responses and 'coerced' volitional actions is the concept of a free decision – or, rather, the intuition that, in both cases, the causee was not able to make a free decision about realizing the effect of a *make*-causative.

fine-grained analysis than our dynamics currently permits. Crucially, what we have designated as the will or desire of an agent for an effect is closer to the notion of an **effective preference** (Condoravdi & Lauer 2016) than to a pure internal desire proposition. For a volitional effect, an effective preference would encode an agent's action-adjacent decision about performing the action, and would be causally influenced not only by internal desires, but also by external considerations. For example, if Gurung succeeded in getting the children to dance in (1b) by bribing them with candy, distinguishing between an effective preference and internal desire would allow us to capture the fact that his bribe is sufficient to produce dancing not because it changes their fundamental attitude towards dancing, but because it makes dancing a means to an end – that is, it changes their decision about whether or not to dance without changing their underlying attitude towards dancing. The degree to which this type of distinction is relevant for sufficiency causatives in English and other languages will have to await further study.

4.2 Causal ‘perfection’

In §2.2 we saw that certain *make* sentences seem to license an inference of (counterfactual) necessity – i.e., that the cause was a necessary condition for the effect to be realized. We showed that these necessity implications could not belong to the entailed content of a *make*-causative, because it is possible both to cancel them and to felicitously use *make* in contexts which explicitly preclude the necessity of the cause for the effect (e.g., the soccer camp example (16)). Nevertheless, many *make* sentences convey (and are evidently intended to convey) a necessity relation as a pragmatic inference. In this section, we discuss how this inference can be explicated on a sufficiency analysis of *make*.

‘Exculpatory’ uses of *make* provide perhaps the clearest example of *make*-causatives which are intended to convey necessity (as well as sufficiency). (48) gives two examples of the exculpatory use.

- (48) a. [title of a linguistics handout in which the author ends up proposing a very complicated analysis]
The data made me do it.
- b. [The speaker is in court, on trial for her participation in the blocking of a coal train in Spokane, Washington. The action was undertaken in an effort to protest global warming.]
?Climate change made me do it.

In both examples, the speaker not only wants to convey that her hand was forced by the cause (i.e., that the coercive implication was true, and she did not make a free decision), but also that she would not have taken the actions she did had she not been forced to do so – that is, if the cause had not been present. This second implication carries the (counterfactual) necessity inference.

Salient as this implication is in such cases – indeed, if (48b) is presented as a legal defense, it may be the main point that the speaker wishes to convey – we believe that it represents a pragmatic enrichment of the entailed content of a *make*-sentence. This claim is supported by applying some the classic implicature tests: cancellability, reinforcement, and calculability.²²

²² It is important to note that, like many linguistic tests, the classic implicature tests can only serve as rough heuristics. They do not always produce reliable results (Sadock 1978); ultimately, whether a pragmatic enrichment passes a particular implicature test depends on the precise manner in which it is derived (Lauer 2013; 2014). This makes them no less valuable as heuristic guidelines.

We have already seen that the necessity inference is optional, or ‘cancellable’ based on context: it is not produced by all uses of causative *make*, most notably those that occur in contexts with which it is incompatible. As noted in §2.2, the first soccer camp example (16) is just such a necessity-denying context (but, crucially, is a fully felicitous use of *make*). It is also possible for a speaker to explicitly suspend a necessity inference without causing infelicity, as in (49).

- (49) Gurung made the children dance, but they might have danced anyway.

Finally, the necessity inference can be freely reinforced, without producing a sense of redundancy:

- (50) The data made me do it. I would never have done it otherwise.

We are unable to present a detailed account here of how the necessity implication of *make* is derived, and thus cannot definitively show that it is calculable. However, we believe that it is predicted by a sufficiency analysis of *make*, by analogy to a previously-established pragmatic inference. That is, if our hypothesis about *make* is correct, the necessity inference can be calculated as a particular instance of a more general pragmatic tendency for expressions of sufficiency to be enriched with necessity relations as well.

This tendency is extremely well known. We refer, of course, to the ‘invited inference’ of **conditional perfection** (Geis & Zwicky 1971), where a conditional statement of the form *If p, (then) q* is taken to additionally convey that *q* is not true in case *p* fails to hold.²³

- (51) If you mow the lawn, I’ll pay you ten dollars.
 ~> *If you do not mow the lawn, I won’t pay you ten dollars.*

The literature on conditional perfection contains a wide range of proposals for the precise mechanism(s) by which it is calculated (see van der Auwera 1997; Horn 2000; von Stechow 2001; Franke 2009; Nadathur 2013; Herburger 2015: among others). However, it is widely agreed that the inference represents a systematic enrichment or strengthening which arises from ‘balancing’ or weighing the entailed content of the conditional statement against the informational needs and context at the point in a discourse where the conditional is used (see also Roberts 2012[1996]: on the *question*

²³ We are grateful to Larry Horn and Lucas Champollion, who (independently) suggested to us that the necessity inference may be an instance of the more general phenomenon of perfection.

under discussion). Insofar as the reasoning involved in evaluating a *make* causative parallels the reasoning used to evaluate conditional statements (see footnote 13), we believe that a successful account of conditional perfection will also parallel or even directly provide an account of the calculation of ‘causal’ perfection – the tendency for statements of causal sufficiency to implicate causal necessity relations as well.²⁴

5 Causal dependencies beyond *make* and *cause*

Although this paper focuses on *make* and *cause*, we believe that the current approach can be extended to other causative verbs: we have already suggested that *let* may be a sufficiency causative in complementary contextual distribution with *make*. Here, we want to suggest that other periphrastic causatives, like *have* and *get*, in (1c)-(1d), should also be analyzed in terms of the particular causal ‘bringing-about’ relationships they predicate.

- (1)
 - a. Gurung caused the children to dance.
 - b. Gurung made the children dance.
 - c. Gurung had the children dance.
 - d. Gurung got the children to dance.

As we noted earlier, the use of *get* or *have* leads to specific inferences about the nature of the causal chain or situation being described. This is particularly striking when *get* and *have* are compared to *cause*, but they also differ from *make* and from one another. On a CAUSE-as-core approach, however, trying to pin down what entailments are specific to *get* (for instance) leads to familiar problems.

In (1d), *get* suggests that Gurung experienced some difficulty in bringing about an (intended) event in which the children danced. This inference

²⁴ We should emphasize that not just any account of conditional perfection will do. Implicature calculations are typically taken to be sensitive to the availability of pragmatic alternatives. Plausibly, the assertion *If p, (then) q* competes with a plain assertion of *q* – some authors argue for a wider range of alternatives (van der Auwera 1997), including the ‘unconditional’ *Whether or not p, q* (Zaefferer 1991). If a successful account of conditional perfection relies on the precise set of relevant alternatives, then the availability of a parallel account for causal perfection will rely on the existence of an analogous or otherwise appropriate set of alternatives to, e.g., a *make*-causative. It is worth noting that, even if it turns out that the correct derivation of conditional perfection cannot be extended to ‘causal perfection’ (though we think this is unlikely to be the case), it remains extremely plausible, if not undeniable, that the necessity inference associated with *make*-causatives is a pragmatic phenomenon, in virtue of the other tests employed here.

has been referred to as the ‘hindrance’ implication of *get*; McIntyre (2005) compares it to the inference of difficulty or effort that is often associated with uses of the implicative verb *manage*, noting that (52) does not seem to differ significantly in meaning from (1d).²⁵

(52) Gurung managed to get the children to dance.

We find the same hindrance implication across a range of naturally-occurring *get*-statements, taking both participial and infinitival complements:

- (53) a. ?So I thought I’d give it a try today, and after a lot of hard work, I got it accepted.
 b. ?I shared some plates and glasses with y’all a good while back and have finally got a table setting put together using them.
 c. ?It’s tempting to think professional interviewers got the president to admit something he didn’t intend to say, but in each of these instances, Trump simply blurted out incriminating thoughts that happened to be on his mind.

(53a) makes it explicit that the result (getting a solution to a mathematical problem accepted) took effort to bring about, which is compatible with both the ‘hindrance’ implication, and the comparison between *get* and *manage*. Similar inferences arise, albeit more implicitly, from (53b) and (53c). In (53b), the use of *finally* suggests that something got in the way of the speaker’s intention to put the table setting together for some extended period of time, thus suggesting a hindrance. In (53c), the speaker indicates that the use of *get* is not appropriate, precisely because no effort on the part of the interviewers was required to cause Trump to blurt out ‘incriminating thoughts.’

The examples in (53) share an important feature, however: they all involve an animate, volitional subject. Causative *get* can also appear with inanimate or eventive subjects. The examples in (54), while compatible with the inference that their results were nontrivial to achieve, certainly do not suggest effort on the part of the cause.

²⁵ McIntyre (2005) discusses the hindrance inference in connection with uses of *get* which take prepositional phrases as their complements, such as (i).

(i) He got the book through customs.

While McIntyre does not deal with *get* examples taking infinitival complements, we believe that the hindrance inference arises in these cases as well.

- (54) a. ?This book got me to think critically about what's on my plate, support local farmers and think about how African cooking is deeply rooted in community.
 b. ?Lovett: How talking on the phone got me arrested in Albany.

Moreover, as (55a)-(55b) show, the hindrance inference can be explicitly denied. Thus, as with the coercive implication of *make*, a hindrance or effort inference cannot be an entailment of a univocal causative *get*.

- (55) a. ?Republicans were very happy as they easily got the President to sign the bills they tried to pass.
 b. ?He EASILY got me to answer his STUPID STUPID unimportant questions more than 30 times.

Our intuition is that the examples in (53)-(55) all predicate a causal bringing-about relationship between their subjects and complements. Moreover, we believe that the bringing-about relations in these examples can be given a uniform analysis if we ask the same question as we did with *make*: what are the features common to all of the causal situations described? Ostensibly, narrowing down these features will allow us to establish the nature of the causal dependence relation predicated by *get*.

Examining a variety of uses of causative *have* leads to a similar analytic conclusion: for example, the 'authoritative' implication associated with (1c) persists in cases with volitional subjects, but vanishes when *have* appears with non-agentive (or eventive) subjects, as in (56). Here, too, we suggest that the right type of 'bringing about' relation can unify the various causative uses of *have*.

- (56) ?From the apocalyptic depiction of our world to the detailed OASIS, the book had me looking up nearly every pop culture reference to find out what it was!

We will not pursue an analysis of either of these verbs here, except to note that, if we are correct that *make* predicates causal sufficiency, while *cause* predicates causal necessity, *get* and *have* might represent particular combinations or configurations of these relations, thus distinguishing the causal situations being described. Alternatively, it might be the case that *get* and *have* specify additional constraints on the bringing-about relations they predicate. For instance, if *have* predicates causal sufficiency, the authoritative implication might arise as a consequence of a requirement that the causal chain be 'short' (with the causing event directly producing the effect), com-

bined with a volitional subject. By contrast, the hindrance implication of *get* might follow from precisely the opposite restriction: a causal chain of length greater than 1, where some additional event or events intervene between the stated cause and effect. Other mutable inferences – for instance, about the intentions of the causer – might then arise from what we know or can infer in context about the nature of any intervening events.

We believe that causal relations have a role to play in semantic analysis outside of the domain of overtly causal language as well. Recent treatments of implicative verbs (*manage*, *dare*), from Baglini & Francez (2016) and Nadathur (2016), take them to presuppose particular types of causal structure, leading to particular inferences – such as a hindrance or difficulty inference – associated with the use of these verbs. Here, again, the similarity between the hindrance implication of *get* and that of *manage* lends support to the idea that a similar analysis should be pursued in each case.

Standard disposition ascriptions, like *fragile* or *water-soluble*, present a particularly interesting case for causal analysis. Like causative verbs, disposition ascriptions are often closely associated with counterfactual statements.

- (57) a. This glass is fragile.
 b. If this glass were (suitably) struck, it would shatter.
- (58) a. This lubricant is water-soluble.
 b. If this lubricant were immersed in water, it would dissolve.

It seems intuitively obvious that such dispositional predicates talk about the causal make-up of the world, insofar as they encapsulate the latent causal consequences of certain actions or event. As is the case with causatives, however, the counterfactuals in (58)-(57) cannot be the full story. They cannot be entailments, at least as stated: we can imagine circumstances (involving ‘reverse-cycle finks,’ or factors ‘masking’ the disposition;²⁶ Martin 1994; Johnston 1992, respectively) in which the dispositional statements are true, but the counterfactual is false.

In a causal-model framework, a disposition can be understood as a hypothetical guarantee: e.g., if some event in which the glass is subjected to a strong impact occurs, the glass will respond in a predetermined way

²⁶ A reverse-cycle fink is a (often quite outlandish) mechanism that ensures that the consequent state (breaking, dissolving) does not actuate by *removing* the disposition whenever its triggering condition (striking, immersing) is actualized. ‘Masking’ refers to much less fanciful cases in which the effect is suppressed by other means: a glass that is carefully wrapped in suitable packing material will continue to be fragile ((57a) is true), even though it would no longer shatter if struck ((57b) is false).

(by breaking). This resembles closely the structure underlying the *make* assertion “Striking the glass made it shatter.” In the case of the disposition, however, we do not require that the ‘causing’ or ‘initiating’ variable is realized. That is, unlike in the *make*-construction, no one need actually strike the glass for the truth of the sentence to be realized. Seen from this perspective, the close connection between disposition ascriptions and counterfactual conditionals would, as in the case of causatives, not come about because one entails the other, but rather because both are interpreted in terms of the same kind of underlying structure.

6 Conclusion

We have argued that the two definitions of causation put forward by Hume (as quoted by Lewis 1973) actually represent two ways in which one event or ‘object’ can cause another. An umbrella notion of causation, at least as we encode it in language is, on our approach, not a single concept, but rather an umbrella notion comprising a set of contrasting ‘bringing-about’ relations. In this paper, we have focused on the relations of causal necessity and causal sufficiency. These relations, as defined over a causal network, are fundamentally different: neither can be fully defined in terms of the other. Moreover, we have argued that both notions arise in lexical semantic representation, by showing that the contrasting inferential profiles of periphrastic causatives *cause* and *make* can be derived by attributing different relations of causal dependence to these two. We have also suggested that other English causatives may express more complex types of causal dependence, or specific configurations of dependence relations.²⁷

If English periphrastic causative describe contrasting causal dependence relations, we reasonably expect periphrastic causatives to be used in similar (and similarly contrastive) ways crosslinguistically. In Lauer & Nadathur (2018), we pursue a sufficiency-based causal dependence account of German *lassen*, which is in some cases best translated as *let* and in others as *make* (see also comments in §4.1). Crucially, different types of relations predict the licensing of different entailments and implicatures. In examining an arbitrary causative, we can use the presence of these inferences to identify underlying relations of causal necessity and/or causal sufficiency. For instance, a causative verb which triggers an implication of coercion in

²⁷ For instance, a plausible causative verb might represent an INUS (insufficient but necessary part of an unnecessary but sufficient condition; proposed by Mackie 1974 as the underlying relation described by *cause*) condition.

cases where the effect involves a volitional action and agent is (for the reasons discussed in §4.1) a good candidate for a sufficiency analysis. On the other hand, a causative which does not seem appropriate in scenarios where there are multiple paths to a particular outcome, or which triggers a (potentially defeasible) inference that it is the only condition in question for the relevant effect, is likely to involve a necessity relation.

It need not be the case, of course, that a causative verb expresses a single basic type of causal dependence. Very plausibly, there may be causatives which express both necessity and sufficiency: we would expect the situations in which such a verb is appropriate to involve rather direct causation. This suggests a possible new approach to the analysis of lexical causatives, which are often argued to entail, along with a CAUSE core and a specific type of effect, the directness of the described causal chain. Along the lines of the analysis proposed here, we might pursue an account of lexical causatives as asserting both causal necessity and causal sufficiency alongside the effect type, and aim to derive the directness implication from the types of appropriate causal structure that this meaning would require, as we did with the coercive implication of *make*.²⁸

Appendix: Sources for naturally-occurring examples

Below, example numbers refer to the number under which the example occurs in the main text.

- (1b) Singing some of the band's ever-popular numbers like Resham, Chekyo chekyo and Jomsome bazarma, Gurung made the children dance and hop to his numbers.

Source: <https://thehimalayantimes.com/entertainment/what-a-treat/>
Last retrieved on: 2019-02-14

- (2a) Yes, I accidentally made [my 3-year old son] fall off the boogie board because holding the board and two bottles of fish food was a little much.

Source: <http://www.trekaroo.com/activities/ko-olina-ocean-adventures->

²⁸ Martin (2018) proposes an alternative in which lexical causatives assert a specific type of sufficiency relation, *ab initio causal sufficiency*, which is definable in a system due to Kwart (2001; 2004) that differs from the dynamics informally sketched here. A comparison of these approaches, along with various other options, will hopefully shed light on the structural requirements of an appropriate causal framework for representing the causal dependencies that occur in natural language.

honolulu-hawaii

Last retrieved on: 2017-06-20

- (2b) Took a picture of my cat and accidentally made him look like a villain!
Source: <https://9gag.com/gag/avPzeDd/took-a-picture-of-my-cat-and-accidentally-made-him-look-like-a-villain>
Last retrieved on: 2018-05-01
- (2c) Instead of motivating him to improve, you've inadvertently made him tune you out.
Source: http://mycrains.crainsnewyork.com/executive_inbox/2009/06/post.html
Last retrieved on: 2017-06-20
- (2d) How Time-Poor Scientists Inadvertently Made It Seem Like The World Was Overrun With Jellyfish.
Source: <http://www.iflscience.com/plants-and-animals/how-timepoor-scientists-inadvertently-made-it-seem-like-the-world-was-overrun-with-jellyfish/>
Last retrieved on: 2018-05-01
- (2e) These were what caused our dog problems back at Lauderdale when I inadvertently made her walk through an area of bush without realizing what I was doing.
Source: http://tonywatton.net.au/25-pieman_tony.html
Last retrieved on: 2018-05-01
- (2f) Jackie Hoffman on How Jessica Lange Unintentionally Made Her Cry
Source: <http://oianews.com/feuds-jackie-hoffman-on-how-jessica-lange-unintentionally-made-her-cry-exclusive-video>
Last retrieved on: 2017-06-20
- (2g) I was panicking and I unintentionally made my friend worry by mentioning the storm through a WhatsApp message and then leaving my phone in my bag, without relaying a message back that everything was actually ok.
Source: <https://areyouhavingabubble.wordpress.com/tag/hurricane/>
Last retrieved on: 2018-05-01
- (3a) I was scared, but they made me feel confident!
Source: https://www.tripadvisor.com/ShowUserReviews-g55328-d1777941-r391405874-Foxfire_Mountain_Adventures-Sevierville_Tennessee.

[html](#)

Last retrieved on: 2017-07-05

- (3b) Demi has previously admitted her mother Diana is her “anchor”, and has made her feel positive about her future once again.
Source: <https://www.ctvnews.ca/demi-lovato-likes-to-celebrate-overcoming-her-demons-1.777583>
Last retrieved on: 2018-05-01
- (3c) Then a surprise surgery and hospital stay at the age of 13 brought Albert in contact with nurses who made her feel happy and important during a stressful situation.
<https://www.apnews.com/454946fca2304c0191745d14f2d728b9>
Last retrieved on: 2018-05-01
- (4a) His father’s death made him turn to the team as family.
Source: <http://www.opencourt-basketball.com/the-assassination-of-his-father-malcolm-made-steve-kerr-the-man-he-is-today/>
Last retrieved on: 2018-04-28
- (4b) This book made me get a divorce.
Source: <https://www.amazon.com/Adonis-Selected-Margellos-Republic-Letters/dp/0300181256>
Last retrieved on: 2017-07-05
- (4c) Too much water made the plant die because the roots rotted in the water.
Source: Newton, Douglas. 2001. *Talking Sense in Science: Helping Children Understand Through Talk*. London: Routledge. <https://doi.org/10.4324/9780203164631>
Last retrieved on: 2018-05-01
- (4d) Stop saying Mussolini made the trains run on time.
Source: <https://www.citylab.com/transportation/2016/11/the-problem-with-mussolini-and-his-trains/507764/>
Last retrieved on: 2018-05-01
- (7) As much as 14 inches fell in Greater Boston on Thursday, leaving more than 24,000 without power by late afternoon as the storm caused what officials called a “historic high tide” to flood coastal towns.
Source: <https://www.washingtonpost.com/news/post-nation/wp/2018/01/04/winter-storm-crashes-into-east-coast-with-snow-and-brutal-cold/>
Last retrieved on: 2018-05-01

- (8) In total, the Napa fires caused approximately \$68,000 in revenue loss to the Vine Transit system.
Source: <http://www.nvta.ca.gov/sites/default/files/Agenda%20Packet%2012-06-2017.pdf>
Last retrieved on: 2018-05-01
- (10a) She [Anand's mother]...made Anand pump the tires [of the bicycle] every morning.
Source: Naipaul, V.S. 1969. *A House for Mr. Biswas*. Harmondsworth, England: Penguin.
Cited after: Wierzbicka (1998)
- (11a) A sharp hiss made her [Alice] draw back in a hurry.
Source: Carroll, Lewis. 1929. *Alice's Adventures in Wonderland*. London: A. & C. Black Ltd.
Cited after: Wierzbicka (1998)
- (15) MADDOW: You worked for [the health insurance company] CIGNA for 15 years, you left last year. What **caused** you to change your mind about what you were doing and leave?
 POTTER: Well, two things. One, it was kind of gradually. One instance or in one regard because I was becoming increasingly skeptical of the kinds of insurance policies that the big insurance companies are promoting and marketing these days. [...]
 The other thing that really **made** me make this final decision to leave the industry occurred when I was visiting family in Tennessee a couple of summers ago, and [narrates the experience of happening on a 'healthcare expedition' where uninsured patients were treated by volunteer doctors in animal stalls at a fairground.]
Source: The Rachel Maddow Show, MSNBC, August 10, 2009
Transcript available at: http://www.nbcnews.com/id/32372208/ns/msnbc_tv-rachel_maddow_show/
Last retrieved on: 2017-07-05
- (47a) Moeen Ali has described an incident that made him turn red in the cricketing field.
Source: <https://www.newsgallery.com/post/moeen-ali-reveals-his-angriest-moment-in-the-cricket-field/4194/>
Last retrieved on: 2019-02-24
- (47b) She has suffered from hyperthyroidism for many years and the disease made her feel dizzy and uneasy even before the disaster.
Source: <http://www.ifrc.org/ar/news-and-media/news-stories/asia->

[pacific/china/specialist-teams-helping-survivors-in-sichuan-following-earthquake-61373/?print=true](https://www.pacific/china/specialist-teams-helping-survivors-in-sichuan-following-earthquake-61373/?print=true)

Last retrieved on: 2019-02-19

- (48b) Climate change made me do it: activists press the ‘Necessity Defense’.
Source: <https://www.forbes.com/sites/legalnewsline/2018/01/10/climate-change-made-me-do-it-activists-press-the-necessity-defense/#721ecb0553e0>
Last retrieved on: 2018-01-25
- (53a) So I thought I’d give it a try today, and after a lot of hard work, I got it accepted.
Source: <https://codeforces.com/blog/entry/51227>
Last retrieved on: 2019-01-03
- (53b) I shared some plates and glasses with y’all a good while back and have finally got a table setting put together using them.
Source: <http://www.savvysouthernstyle.net/2011/06/tablescape-that-finally-got-completed.html>
Last retrieved on: 2019-01-03
- (53c) It’s tempting to think professional interviewers got the president to admit something he didn’t intend to say, but in each of these instances, Trump simply blurted out incriminating thoughts that happened to be on his mind.
Source: <http://www.msnbc.com/rachel-maddow-show/trump-says-more-he-shouldve-about-his-acting-attorney-general>
Last retrieved on: 2019-01-03
- (54a) This book got me to think critically about what’s on my plate, support local farmers, and think about how African cooking is deeply rooted in community.
Source: <http://blackfoodie.co/afrovegan>
Last retrieved on: 2019-01-06
- (54b) Lovett: How talking on the phone got me arrested in Albany.
Source: <http://www.nydailynews.com/news/politics/lovet-talking-phone-arrested-albany-article-1.3902185>
Last retrieved on: 2018-05-01
- (55a) Republicans were very happy as they easily got the President to sign the bills they tried to pass.
Source: <https://owlcation.com/humanities/Warren-Harding-29th->

President

Last retrieved on: 2019-01-06

- (55b) He EASILY got me to answer his STUPID STUPID unimportant questions more than 30 times.

Source: <https://coryadventures.wordpress.com/2011/07/>

Last retrieved on: 2019-01-06

- (56) From the apocalyptic depiction of our world to the detailed OASIS, the book had me looking up nearly every pop culture reference to find out what it was!

Source: <https://www.commonsemmedia.org/book-reviews/ready-player-one/user-reviews/child>

Last retrieved on: 2018-05-01

Acknowledgements

Much of section 2 of this paper has antecedents in a manuscript by one of the authors (Lauer 2010), which lay fallow for many years. That manuscript benefitted immensely from comments, discussion and guidance by Beth Levin, Cleo Condoravdi, Paul Kiparsky, the participants of the workshop on Causality, Counterfactuals, and Inertia in Stanford (the ‘N3C’ workshop), as well as the participants of the Semantics Research Meetings at Stanford in the Fall of 2009. Larry Horn and Lucas Champollion also influenced this manuscript, by suggesting that we consider an analogue to ‘conditional perfection’ in the causal domain.

Since the earlier manuscript was completed, parts of this material have been presented at Annual LSA Meeting in Pittsburgh, 2011, the Workshop on aspect and modality in lexical semantics at the University of Stuttgart, 2011, and the Workshop on representing causal dependencies in formal semantics at the University of Konstanz, 2017. We are grateful to audiences at these occasions for valuable feedback, discussion and comments, especially to Fabienne Martin, Hans Kamp, Chris Piñon, Antje Rumberg and Katrin Schulz. We are also indebted to three anonymous reviewers at *Glossa* for thoughtful feedback which resulted in significant revisions to the structure and content of this manuscript, and once again to Cleo Condoravdi for insight and suggestions throughout this process.

References

- Baglini, Rebekah & Itamar Francez. 2016. The implications of managing. *Journal of Semantics* 33(3). 541–560. <http://dx.doi.org/10.1093/jos/ffv007>.
- Barwise, Jon & J. Perry. 1981. Situations and attitudes. *The Journal of Philosophy* 78(11). 668–691. <http://dx.doi.org/10.2307/2219775>.
- Condoravdi, Cleo & Sven Lauer. 2016. Anankastic conditionals are just conditionals. *Semantics and Pragmatics* 9(8). 1–69. <http://dx.doi.org/10.3765/sp.9.8>.
- Copley, Bridget & Phillip Wolff. 2014. Theories of causation should inform linguistic theories and vice versa. In Bridget Copley & Fabienne Martin (eds.), *Causation in grammatical structures*, 11–57. Oxford: Oxford University Press. <http://dx.doi.org/10.1093/acprof:oso/9780199672073.003.0002>.
- Cruse, David. 1972. A note on english causatives. *Linguistic Inquiry* 3(4). 522–528.
- Dixon, Robert M. W. 2005. *A semantic approach to English grammar* (Oxford Textbooks in Linguistics). Oxford: Oxford University Press.
- Dowty, David. 1979. *Word meaning and Montague Grammar*. Dordrecht: Reidel.
- Franke, Michael. 2009. *Signal to act: Game theory and pragmatics*. Amsterdam: Universiteit van Amsterdam dissertation.
- Geis, Michael & Arnold Zwicky. 1971. On invited inferences. *Linguistic Inquiry* 2(4). 561–566.
- Hall, Ned. 2004. Two concepts of causation. In John Collins, Ned Hall & Lauri A. Paul (eds.), *Causation and counterfactuals*, 225–276. Cambridge, MA: MIT Press.
- Halpern, Joseph Y. 2015. A modification of the Halpern-Pearl definition of causality. In Qiang Yang & Michael Wooldridge (eds.), *Proceedings of the Twenty-Fourth International Joint Conference on Artificial Intelligence (IJCAI 24)*, 3022–3033. Palo Alto, CA: AAAI Press.
- Halpern, Joseph Y. & Judea Pearl. 2005. Causes and explanations: A structural-model approach – Part I: Causes. *British Journal of Philosophy of Science* 56. 843–887. <http://dx.doi.org/10.1093/bjps/axi147>.
- Herburger, Elena. 2015. Conditional perfection: the truth and the whole truth. In Sarah D’Antonio, Mary Moroney & Carol Rose Little (eds.), *Proceedings of Semantics and Linguistic Theory*, vol. 25. 615–635. <http://dx.doi.org/10.3765/salt.v25i0.3079>.

- Hitchcock, Christopher. 2010. Probabilistic causation. <http://plato.stanford.edu/entries/causation-probabilistic>.
- Hobbs, Jerry. 2005. Toward a useful concept of causality for lexical semantics. *Journal of Semantics* 22(2). 181–209. <http://dx.doi.org/10.1093/jos/ffh024>.
- Horn, Laurence. 2000. From if to iff: conditional perfection as pragmatic strengthening. *Journal of Pragmatics* 32(3). 289–326. [http://dx.doi.org/10.1016/S0378-2166\(99\)00053-3](http://dx.doi.org/10.1016/S0378-2166(99)00053-3).
- Horn, Laurence R. 2010. Scalarity and polarity: What's the point? Talk given at the SCALE workshop, Stanford University, April 2010.
- Johnston, Mark. 1992. How to speak of the colors. *Philosophical Studies* 68(3). 221–263. <http://dx.doi.org/10.1007/BF00694847>.
- Kistler, Max. 2006. *Causation and laws of nature*. New York: Routledge.
- Kratzer, Angelika. 1981. The notional category of modality. In Hans-Jürgen Eikmeyer & Hannes Rieser (eds.), *Words, worlds, and contexts. New approaches in word semantics*, 38–74. Berlin: de Gruyter.
- Kratzer, Angelika. 1989. An investigation of the lumps of thought. *Linguistics and Philosophy* 12(5). 607–653. <http://dx.doi.org/10.1007/BF00627775>.
- Kvart, Igal. 2001. The counterfactual analysis of cause. *Synthese* 127(3). 389–427. <http://dx.doi.org/10.1023/A:1010398724481>.
- Kvart, Igal. 2004. Causation: probabilistic and counterfactual analyses. In Edward Hall, John Collins & L.A. Paul (eds.), *Causation and counterfactuals*, The MIT Press.
- Lauer, Sven. 2010. Periphrastic causative verbs in english: What do they mean? the expression of causal necessity and causal sufficiency in ordinary english. Manuscript, Stanford University, 2010.
- Lauer, Sven. 2013. *Towards a dynamic pragmatics*. Stanford, CA: Stanford University dissertation.
- Lauer, Sven. 2014. Mandatory implicatures in Gricean pragmatics. In N. D. Goodman, Michael Franke & Judith Degen (eds.), *Formal & experimental pragmatics*. 21–28. Tübingen.
- Lauer, Sven & Prerna Nadathur. 2018. Sufficiency causatives. Manuscript, in revision.
- Levin, Beth & Malka Rappaport Hovav. 1994. A preliminary analysis of causative verbs in english. *Lingua* 92. 35–77. [http://dx.doi.org/10.1016/0024-3841\(94\)90337-9](http://dx.doi.org/10.1016/0024-3841(94)90337-9).
- Lewis, David. 1973. Causation. *Journal of Philosophy* 70(17). 556–567. <http://dx.doi.org/10.2307/2025310>.

- Lewis, David. 2000. Causation as influence. *Journal of Philosophy* 97(4). 182–197. <http://dx.doi.org/10.2307/2678389>.
- Lifschitz, Vladimir. 1990. Frames in the space of situations. *Artificial Intelligence* 46(3). 365–376. [http://dx.doi.org/10.1016/0004-3702\(90\)90021-Q](http://dx.doi.org/10.1016/0004-3702(90)90021-Q).
- Mackie, John. 1974. *The cement of the universe: A study of causation*. Oxford: Oxford University Press.
- Martin, Charles B. 1994. Dispositions and conditionals. *The Philosophical Quarterly* 44(174). 1–8. <http://dx.doi.org/10.2307/2220143>.
- Martin, Fabienne. 2018. Time in probabilistic causation: direct vs. indirect uses of lexical causative verbs. In *Proceedings of Sinn und Bedeutung* 22.
- McCawley, James. 1978. Conversational implicature and the lexicon. In Peter Cole (ed.), *Pragmatics*, vol. 9 (Syntax and Semantics), 245–259. Academic Press.
- McIntyre, Andrew. 2005. The semantic and syntactic decomposition of *get*: an interaction between verb meaning and particle placement. *Journal of Semantics* 22(4). 401–438. <http://dx.doi.org/10.1093/jos/ffh019>.
- Menzies, Peter. 2017. Counterfactual theories of causation. In Edward N. Zalta (ed.), *The stanford encyclopedia of philosophy*, Metaphysics Research Lab, Stanford University winter 2017 edn. <https://plato.stanford.edu/archives/win2017/entries/causation-counterfactual/>.
- Nadathur, Prerna. 2013. *If ... (and only if): conditional perfection and completeness*. Oxford: University of Oxford MPhil thesis.
- Nadathur, Prerna. 2016. Causal necessity and sufficiency in implicativity. *Semantics and Linguistic Theory (SALT)* 26. 1002–1021. <http://dx.doi.org/10.3765/salt.v26i0.3863>.
- Paul, L.A. & Ned Hall. 2013. *Causation: a user's guide*. Oxford: Oxford University Press.
- Pearl, Judea. 2000. *Causality*. Cambridge: Cambridge University Press. <http://dx.doi.org/10.1017/CBO9780511803161>.
- Ramsey, Frank P. 1931. General propositions and causality. In *The foundations of mathematics and other logical essays*, London: Routledge and Kegan Paul.
- Reiter, Raymond. 1978. On closed world data bases. In H. Gallaire & J. Minker (eds.), *Logic and data bases*, 55–76. Plenum Press.
- Roberts, Craige. 2012[1996]. Information structure: towards an integrated formal theory of pragmatics. *Semantics and Pragmatics* 5(6). 1–69. <http://dx.doi.org/10.3765/sp.5.6>.
- Sadock, Jerrold M. 1978. On testing for conversational implicature. In *Syntax and semantics 9: Pragmatics*, 281–297. New York: Academic Press.

- Schulz, Katrin. 2007. *Minimal models in semantics and pragmatics. free choice, exhaustivity, and conditionals*. Amsterdam: Universiteit van Amsterdam dissertation.
- Schulz, Katrin. 2011. "If you'd wiggled A, then B would've changed": Causality and counterfactual conditionals. *Synthese* 179(2). 239–251. <http://dx.doi.org/10.1007/s11229-010-9780-9>.
- Shibatani, Masayoshi. 1976. The grammar of causative constructions: A conspectus. In Masayoshi Shibatani (ed.), *The grammar of causative constructions*, vol. 6 (Syntax and Semantics), 1–40. New York: Academic Press.
- Sosa, Ernest & Michael Tooley. 1993. *Causation*. Oxford: Oxford University Press.
- Stefanowitsch, Anatol. 2001. *Constructing causation: A construction grammar approach to analytic causatives*. Houston, TX: Rice University dissertation.
- Talmy, Leonard. 1988. Force dynamics in language and cognition. *Cognitive Science* 12(1). 49–100. http://dx.doi.org/10.1207/s15516709cog1201_2.
- van der Auwera, Johan. 1997. Pragmatics in the last quarter century: the case of conditional perfection. *Journal of Pragmatics* 27(3). 261–274. [http://dx.doi.org/10.1016/s0378-2166\(96\)00058-6](http://dx.doi.org/10.1016/s0378-2166(96)00058-6).
- von Stechow, Kai. 2001. Conditional strengthening: a case study in implicature. Manuscript, MIT.
- Walsh, Clare & Steven Sloman. 2004. The meaning of cause and prevent: the role of causal mechanism. *Mind and Language* 26(1). 21–52. <http://dx.doi.org/10.1111/j.1468-0017.2010.01409.x>.
- Wierzbicka, Anna. 1998. The semantics of English causative constructions in a universal-typological perspective. In Michael Tomasello (ed.), *The new psychology of language: Cognitive and functional approaches to language structure*, 113–153. Mahwah, NJ: Lawrence Erlbaum.
- Wolff, Phillip. 2003. Direct causation in the linguistic coding and individuation of causal events. *Cognition* 88(1). 1–48. [http://dx.doi.org/10.1016/S0010-0277\(03\)00004-0](http://dx.doi.org/10.1016/S0010-0277(03)00004-0).
- Wolff, Phillip. 2007. Representing causation. *Journal of Experimental Psychology: General* 136(1). 82–111. <http://dx.doi.org/10.1037/0096-3445.136.1.82>.
- Woodward, James. 2003. *Making things happen: A theory of causal explanation*. Oxford: Oxford University Press.
- Zaefferer, Dietmar. 1991. Conditional and unconditionals: cross-linguistic and logical aspects. In Dietmar Zaefferer (ed.), *Semantic universals and universal semantics*, Berlin: Foris Publications.